

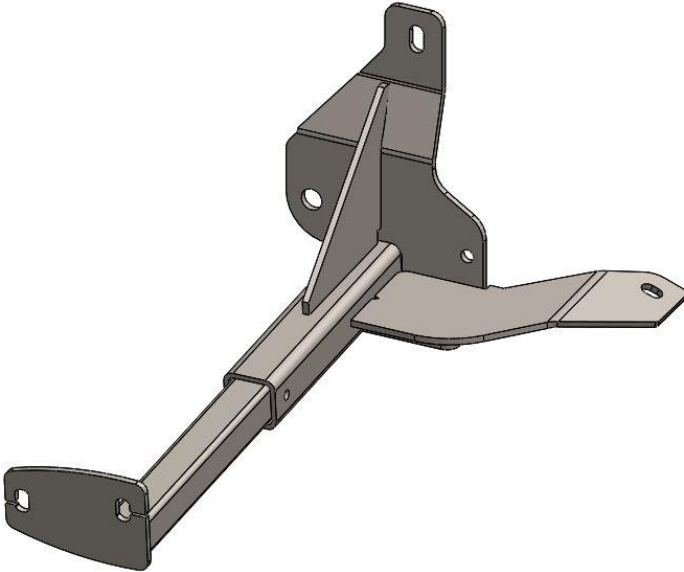

**OVER 35 YEARS OF INNOVATION, QUALITY, SAFETY.  
IMPORTANT OWNER-OPERATOR INSTALLATION INSTRUCTIONS**

## **F2019, F2020**



Version Number: 2, Date: 1/14/2016 By: CW

**TECH SUPPORT (800) 246-8132**

**AFTER INSTALL, PLEASE GIVE  
THIS BOOKLET TO YOUR CUSTOMER**

# Warnings

## Truck Bed and Camper Protection

Torklift **does not** recommend installing your camper on top of a plastic bed liner (or other compressible material such as foam). These materials can act as a spring, causing increased vertical truck camper movement independent of the vehicle. Plastic bed liners can slide on the truck bed surface, and the truck camper can slide on top of the bed liner. Using a plastic bed liner or similar compressible material will void your warranty and may additionally cause truck bed and/or camper damage.









Minor movement or settling can occur in some incidental harsh driving conditions (on or off-road). A rubber bed mat is recommended to protect the truck bed and camper, but is not a requirement to maintain the Torklift legendary lifetime warranty.

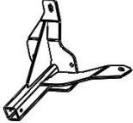
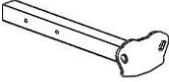
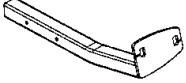



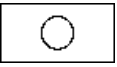

## Suspension

To significantly reduce body roll, sag and sway Torklift strongly recommends the StableLoad. Torklift International StableLoads improve safety, handling, and to help level your truck. More information can be found at ([www.Torklift.com/stableload](http://www.Torklift.com/stableload)).

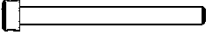
If your truck is additionally equipped with suspension air bags Torklift cautions against over pressurization as this may lead to unsafe vehicle handling characteristics. We have found that airbags used in conjunction with StableLoads have allowed operators to lower air bag pressure by 50% or more. Only pressurize suspension air bags enough to level the truck.

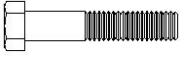
## Parts Inventory

Item Image	Item Description	Quantity
	Tie Down Receiver	2
	Straight Tie Down Insert (F2019 Only)	2
	Bend Tie Down Insert (F2020 Only)	2
	3/4" Flat Washer	2
	M18-2.5 Jam Nut with Thread Locker	2
	1/2"-13 x 2" Grade 8 Hex Bolt	4
	1" x 2" Plate Washer	4
	1/2" Star Washer	4
	1/2" USS Flat Washer	8
	1/2" Lock Washer	4
	1/2"-13 Grade 8 Hex Nut	4

Item Image	Item Description	Quantity
	1/2" Bolt Fisher	2
	1/4" x 2-1/4" Snapper Pin	2
	3/8" x 3/4" x 1" Nylon Spacer	1
	1" OD 1/8" Wall x 1" SS Tube	1
	3/8"-16 x 2.5" Grade 5 Hex Bolt	1
	3/8"-16 Grade 5 Hex Nut	1
	3/8" SAE SS Flat Washer	2
	3/8" Lock Washer	1

## Step 1

Begin the installation on the passenger side of the vehicle. Using a 27mm socket, remove the lock nut from the front leaf spring bolt as shown in figure 1.1. Leave the bolt in place.

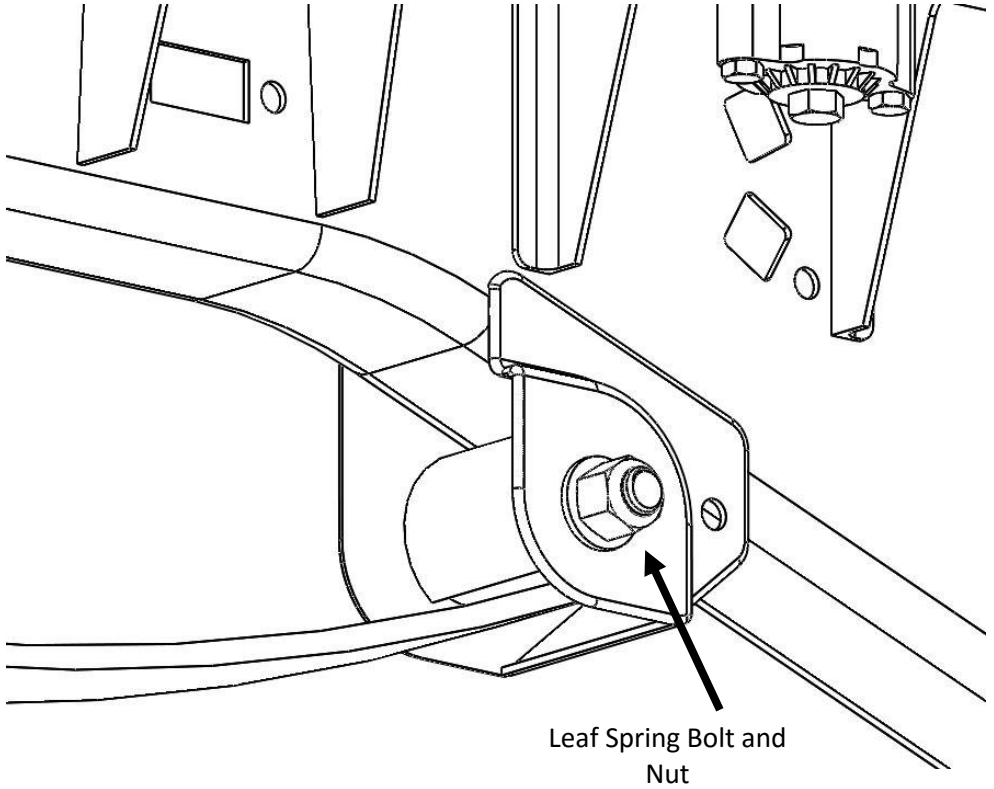

**Figure 1.1**

## Step 2

Install a **1/2"-13 x 2" Grade 8 Hex Bolt** with one **1/2" Star Washer** and one **1" x 2" Plate Washer** onto the coiled end of a **1/2" Bolt Fisher**. See figure 2.1. Insert the hardware, bolt first, into the square hole "A" (see figure 2.2). Using the bolt fisher, pull the hardware back out so the threaded end of the bolt is sticking out of the frame. Leave the bolt fisher attached at this time.

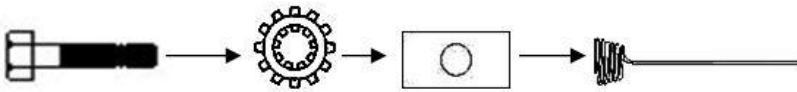

Figure 2.1

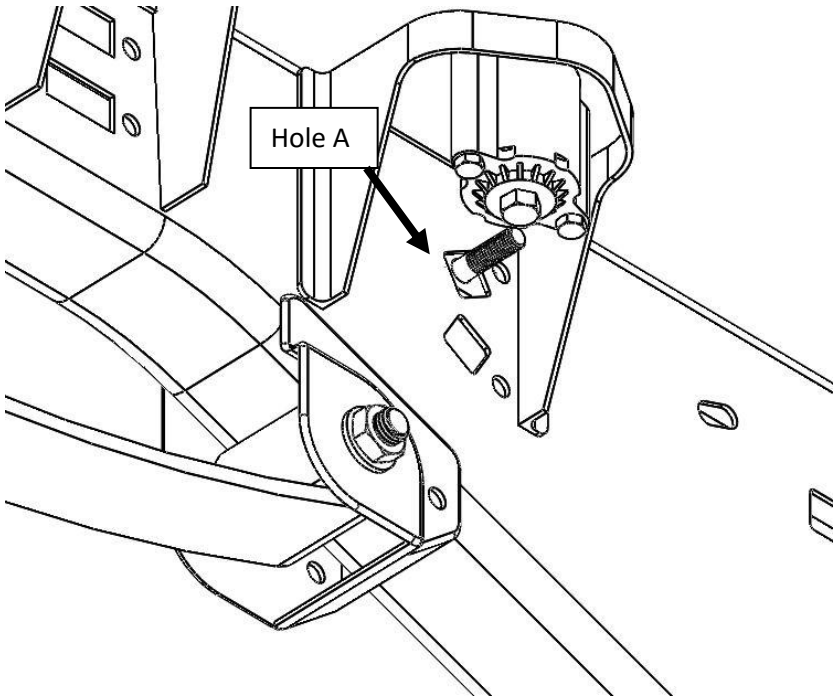
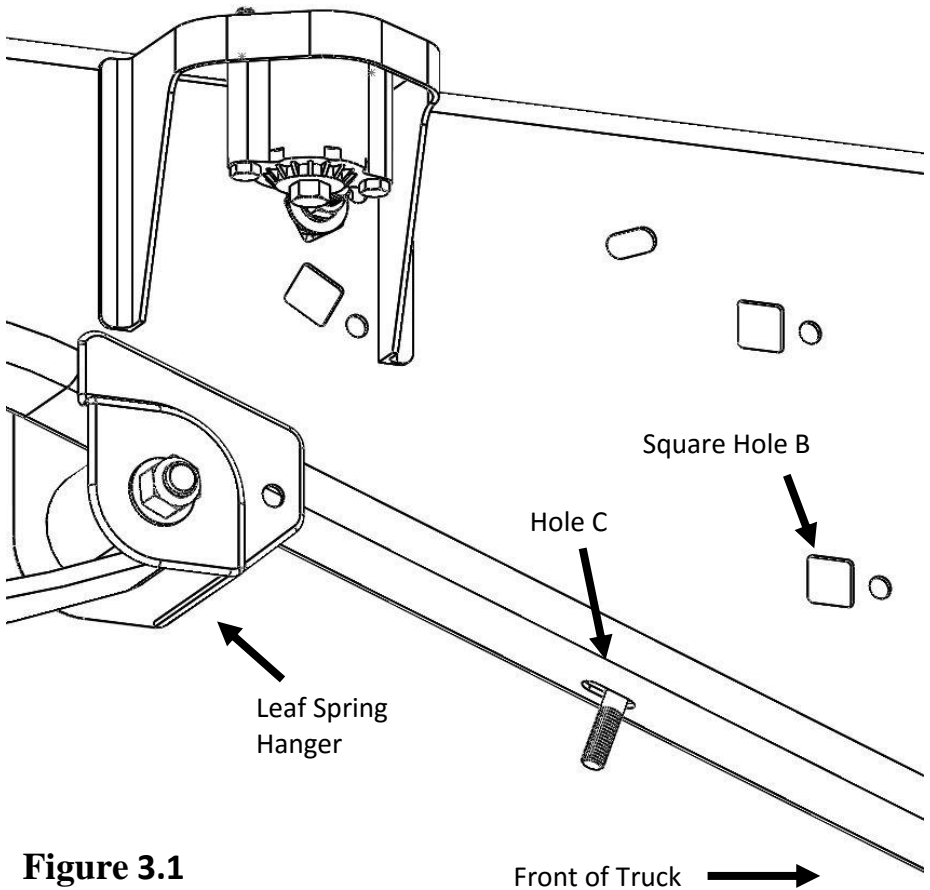

Figure 2.2

### Step 3

Attach a **1/2"-13 x 2" Grade 8 Hex Bolt** with one **1/2" Star Washer** and one **1" x 2" Plate Washer** onto a **1/2" Bolt Fisher**. See figure 2.1. Insert the non-coiled end of the bolt fisher into square hole "B" and back out through the oval hole "C" on the bottom of the frame (just forward of the leaf spring hanger). Pull the hardware through the frame so the threaded end of the bolt protrudes down through the bottom of the frame. See figure 3.1.



**Figure 3.1**

## Step 4

Feed the wire end of the bolt fisher from step 2 into the top hole in the tie down receiver. Feed the wire end of the bolt fisher in step 3 through the hole in the receiver gusset arm. Carefully angle the top of the tie down receiver behind the truck cab mount and up against the frame. The bottom hole in the tie down receiver will slide over the leaf spring bolt. See figure 4.1 and figure 5.1.

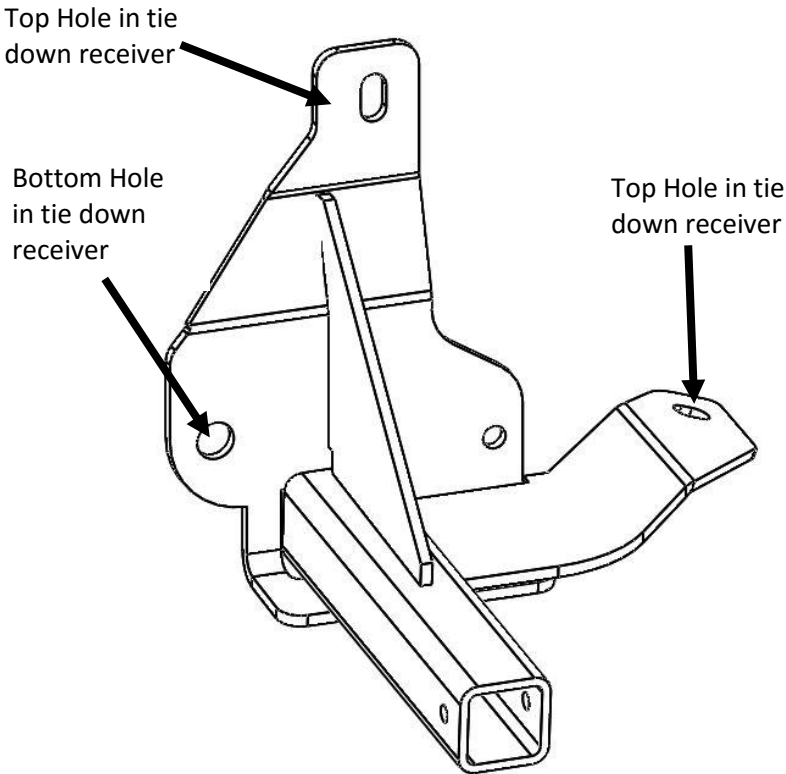
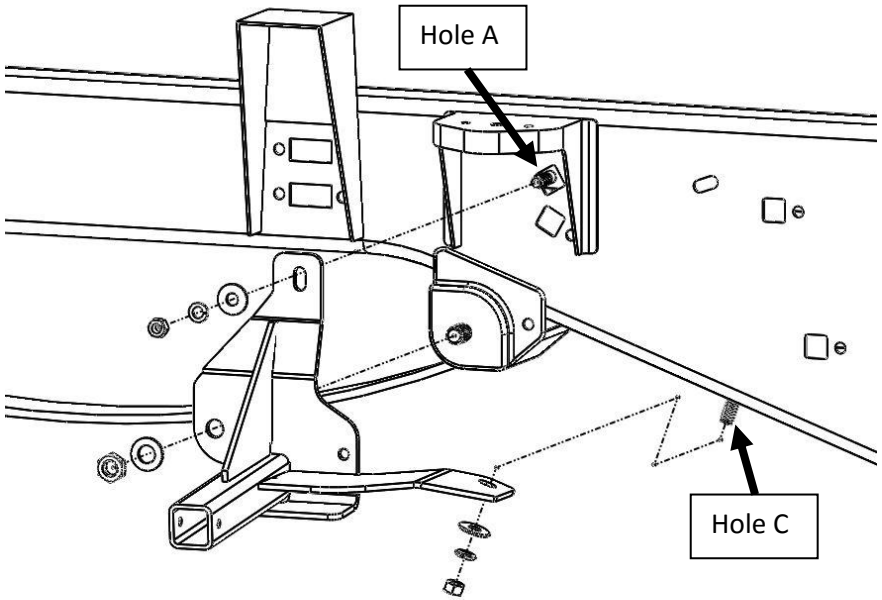

**Figure 4.1**

## Step 5

Secure the Leaf Spring Bolt with one **3/4" Flat Washer** and one **18mm-2.5 Jam Nut** with Thread Locker.

Carefully remove the bolt fisher from the bolt in Hole A. While holding the bolt to keep it from falling into the frame, secure it with one **1/2" USS Flat Washer**, one **1/2" Lock Washer**, and one **1/2"-13 Hex Nut**. It will be necessary to tighten the nut with a 3/4" wrench, as a socket will not be able to reach behind the cab mount. It may be necessary to hold the end of the bolt with channel locks while tightening the nut until the star washer inside the frame begins to grab. Repeat the process for the bolt in Hole C. See figure 5.1



**Figure 5.1 (cab mount not shown for clarity)**

## Step 6

Tighten all 1/2" hardware to 50-ft-lbs (68nm)

Tighten the **M18-2.5 Jam Nut** to 75 ft-lbs (100nm)

## Step 7

Repeat the installation process on the driver side of the vehicle. If your F150 is equipped with mechanical parking brakes, you will need to first remove the parking brake cable bracket from the bottom of the front leaf spring hanger. Install the tie down with the parking brake cables hanging below the tie down receiver.

Once the tie down is installed, reinstall the parking brake cable bracket to the back side of the tie down receiver as shown in figure 7.1. The parking brake cable bracket may need to be bent to fit around the tie down receiver. Make sure the parking brake cables will clear the leaf spring and bed side step if applicable.

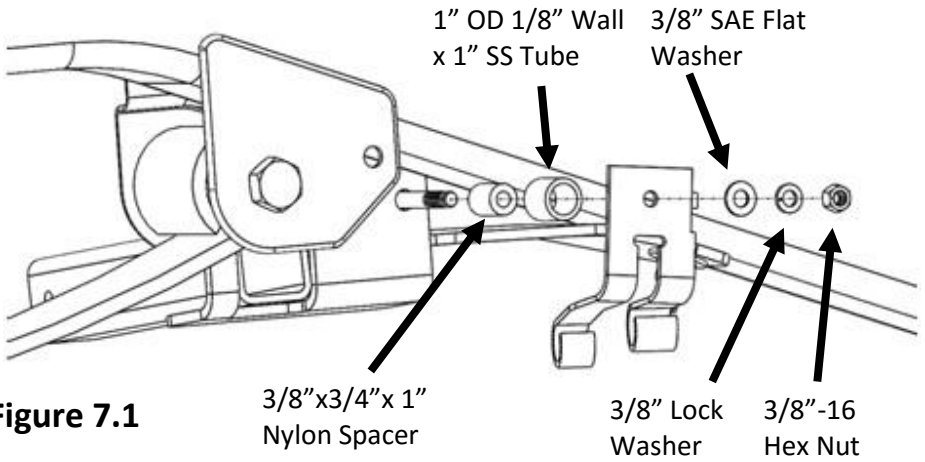
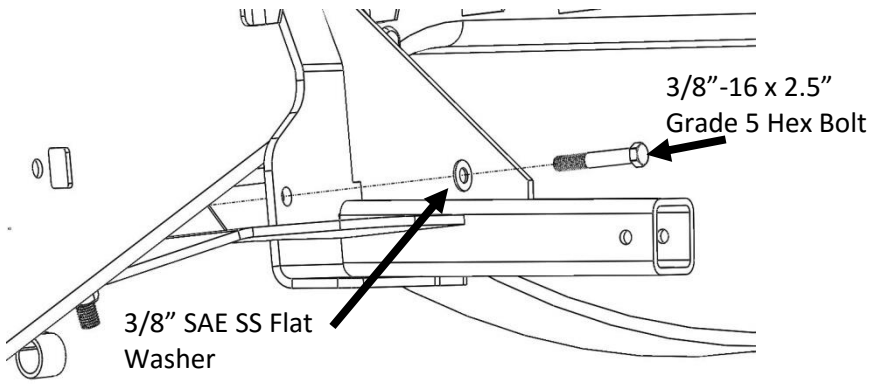

**Figure 7.1**

3/8"x3/4"x 1"  
Nylon Spacer

3/8" Lock Washer  
3/8"-16 Hex Nut

## Step 8

Install the front inserts with the welded plate offset towards the rear of the vehicle, this provides clearance to open the doors with the turnbuckles installed.

**IMPORTANT NOTE:** Your tie down inserts are designed to have clearance inside of the receiver. This is to account for road debris, as well as aid in installation and removal. Some rattle may be expected if the inserts are left installed while not under load from the camper.

# **Torklift International Limited Lifetime Warranty Information**

322 Railroad Ave North, Kent, WA 98032

Torklift will require proof of purchase to register, with pictures of any defective product before issuing a replacement. Torklift will not register any product without proof of purchase, which can be faxed, scanned, emailed, or mailed to the information provided below. Torklift warrants its hitches, custom hitch receivers, frame mounted tie downs, turnbuckles, and accessories (excluding wire harnesses which carry a 90 day warranty) from date of purchase against defects in material and workmanship under normal use and service for the ownership life of the original consumer purchaser. All plastic, rubber, and/ or electrical components maintain a warranty of up to one year from the date of the purchase. **ALL COMMERCIAL APPLICATIONS ARE WARRANTED FOR A PERIOD OF 90 DAYS FROM THE DATE OF INSTALLATION/SERVICE.** Torklift will replace **FREE OF CHARGE** any part which proves defective in material or workmanship when presented to Torklift, **TRANSPORTATION CHARGES PREPAID** by purchaser, at the address above. **THIS WARRANTY IS LIMITED TO DEFECTIVE PARTS REPLACEMENT ONLY. LABOR CHARGES AND/OR DAMAGE INCURRED IN INSTALLATION OR REPLACEMENT, AS WELL AS INCIDENTAL AND CONSEQUENTIAL DAMAGES CONNECTED THEREWITH ARE EXCLUDED.** This warranty does not include the finish or paint on our products. Rusting, cracking or peeling of the finish is also excluded. Some states do not allow the exclusion or limitation of incidental or consequential damages, so the above limitation or exclusion may not apply to you. Any damage to Torklift products as a result of misuse, abuse, neglect, accident, improper installation or any use violation of instructions furnished by Torklift or **WHEN USED IN ANY COMMERCIAL APPLICATION WILL VOID THE WARRANTY.** This warranty gives you specific legal rights, and you may also have rights which vary from state to state. With warranty service, you may be able to go to a small claims court, a state court or a federal district court.



## ***INTERNATIONAL***

**322 Railroad Ave North, Kent, WA 98032**

**Phone (800) 246-8132 Fax (253) 854-8003**

**Or visit our website: [www.TorkLift.com](http://www.TorkLift.com)**

Dear Valued Customer,

Thank you for making TorkLift your choice for truck, camper packages and accessories for your vehicle. By choosing TorkLift products, you have chosen a company that has been serving the RV industry for nearly 40 years and whose name has become synonymous with strength, quality and advanced design and installation.

Please take a few moments of your time to complete the Product Registration Warranty Card on the next page. When registering your newly purchased TorkLift products, you can be assured that your contact information is secure and that you and your product are getting the attention and respect that you deserve.

Thank you again for choosing TorkLift quality products.

**Register for your lifetime warranty and receive a free Torklift International gift.**

To Fax: Send copies of the questionnaire, warranty card and receipt to  
253-854-8003

To E-mail: Send copies of the questionnaire, warranty card and receipt to  
[warranty@torklift.com](mailto:warranty@torklift.com)

To Mail: Send to Torklift International 322 Railroad Ave North, Kent, WA 98032



## OFFICIAL WARRANTY REGISTRATION CARD

**322 Railroad Ave North, Kent, Wa 98032**

Please fill out this form completely and return to Torklift within 30 days of purchase accompanied by a copy of your original receipt

### 1. PART(S) PURCHASED

TODAY'S DATE: \_\_\_\_\_

PART#: \_\_\_\_\_ PART#: \_\_\_\_\_

PART#: \_\_\_\_\_ PART#: \_\_\_\_\_

PART#: \_\_\_\_\_ PART#: \_\_\_\_\_

### 2. PURCHASER INFORMATION

NAME: \_\_\_\_\_

ADDRESS: \_\_\_\_\_

CITY: \_\_\_\_\_ STATE: \_\_\_\_\_ ZIP / POSTAL CODE: \_\_\_\_\_

PHONE: (\_\_\_\_) \_\_\_\_\_ - \_\_\_\_\_ EMAIL: \_\_\_\_\_

### 3. TRUCK INFORMATION

YEAR: \_\_\_\_\_ MAKE: \_\_\_\_\_

MODEL: \_\_\_\_\_ BED LENGTH: \_\_\_\_\_

### 4. CAMPER INFORMATION

YEAR: \_\_\_\_\_ MAKE: \_\_\_\_\_ MODEL: \_\_\_\_\_

### 5. DEALER INFORMATION

PURCHASED FROM: \_\_\_\_\_

ADDRESS: \_\_\_\_\_

CITY: \_\_\_\_\_ STATE: \_\_\_\_\_ ZIP / POSTAL: \_\_\_\_\_

INSTALLED BY: \_\_\_\_\_ OWNER ABOVE DEALER ANOTHER DEALER

IF ANOTHER DEALER, WHO: \_\_\_\_\_