



TORKLIFT

I N T E R N A T I O N A L

**OVER 40 YEARS OF INNOVATION, QUALITY, SAFETY.
IMPORTANT OWNER-OPERATOR INSTALLATION INSTRUCTIONS**

F2021

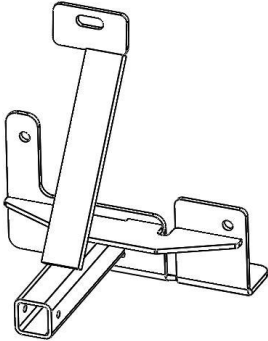

Passenger

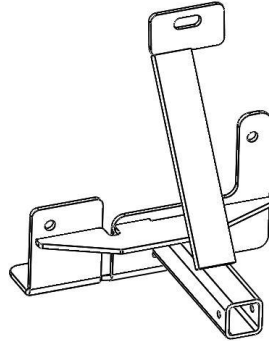

Driver



Version (2) BY: CW

TECH SUPPORT (800) 246-8132

**AFTER INSTALL, PLEASE GIVE
THIS BOOKLET TO YOUR CUSTOMER**

Warnings

Truck Bed and Camper Protection

Torklift **does not** recommend installing your camper on top of a plastic bed liner (or other compressible material such as foam). These materials can act as a spring, causing increased vertical truck camper movement independent of the vehicle. Plastic bed liners can slide on the truck bed surface, and the truck camper can slide on top of the bed liner. Using a plastic bed liner or similar compressible material will void your warranty and may additionally cause truck bed and/or camper damage.











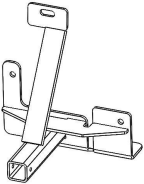

Minor movement or settling can occur in some incidental harsh driving conditions (on or off-road). A rubber bed mat is recommended to protect the truck bed and camper, but is not a requirement to maintain the Torklift legendary lifetime warranty.

Suspension

To significantly reduce body roll, sag and sway Torklift strongly recommends the StableLoad. Torklift International StableLoads improve safety, handling, and to help level your truck. More information can be found at (www.Torklift.com/stableload).

If your truck is additionally equipped with suspension air bags Torklift cautions against over pressurization as this may lead to unsafe vehicle handling characteristics. We have found that airbags used in conjunction with StableLoads have allowed operators to lower air bag pressure by 50% or more. Only pressurize suspension air bags enough to level the truck.

Parts Inventory

Item Image	Item Description	Quantity
	Tie Down Receiver (Passenger Side Shown)	2
	17.875" Straight Tie Down Insert	2
	1/4" x 2 1/4" Bail Pins	2
	1/2" -13 x 2-1/2" Grade 5 Hex Bolt	4
	1/2" -13 x 2" Grade 5 Hex Bolt	4
	1/2" -13 Grade 5 Nut	8
	1/2" USS Washers	8
	1/2" Lock Washers	8
	1/2" Star Washers	8
	1" x 2" Plate Washers	8
	2" x 2" Plate Washers	4
	1/2" Bolt Fisher	3

Installation Instructions

Step 1:

Starting on the passenger side of the vehicle, identify bolt hole locations: A, B, C, D on truck frame. Location is in front of the rear leaf springs.

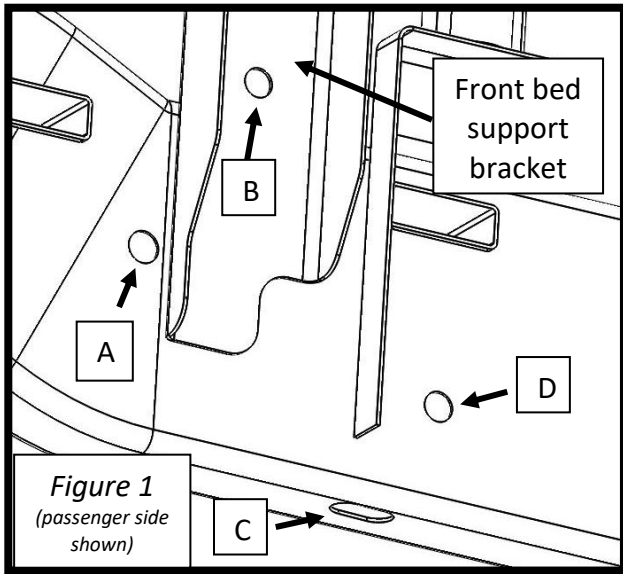

Step 2:

Holes A, C and D will require the use of Bolt Fishers.

Hole A:

- Guide the coiled end of one bolt fisher into Hole A and out of Hole C. Do not allow the straight end of the bolt fisher to fall into the frame.
- Attach one 1" x 2" Plate Washer , one 1/2" Star Washer, and one 1/2"-13 x 2" Grade 5 Hex Bolt onto the coiled end of the Bolt Fisher. See Figure 2

- Feed each piece of hardware into the frame. Be careful not to let the straight end of the Bolt Fisher drop into the frame.

Hole D:

- Repeat the process to fish one 1" x 2" Plate Washer , one 1/2" Star Washer, and one 1/2"-13 x 2-1/2" Grade 5 Hex Bolt From Hole C to hole D.
- Leave the hardware inside the frame, with the straight end of the bolt fisher protruding from Hole D.

Hole C:

- Attach one 1" x 2" Plate Washer , one 1/2" Star Washer, and one 1/2"-13 x 2-1/2" Grade 5 Hex Bolt onto the coiled end of the bolt fisher as seen in Figure 2.
- Insert the hardware into Hole C so that the hardware is in the frame. Leave the straight end of the bolt fisher protruding from Hole C

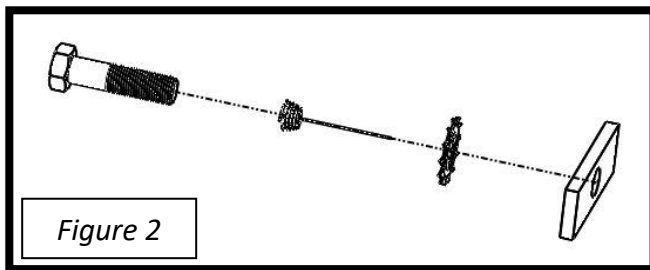

Step 3:

- Place one 2" x 2" Plate Washer over the straight end of each bolt fisher protruding from Hole D and Hole C
- Guide the straight end of each of the three bolt fishers through their corresponding holes in the Tie Down Receiver (see Figure 3).

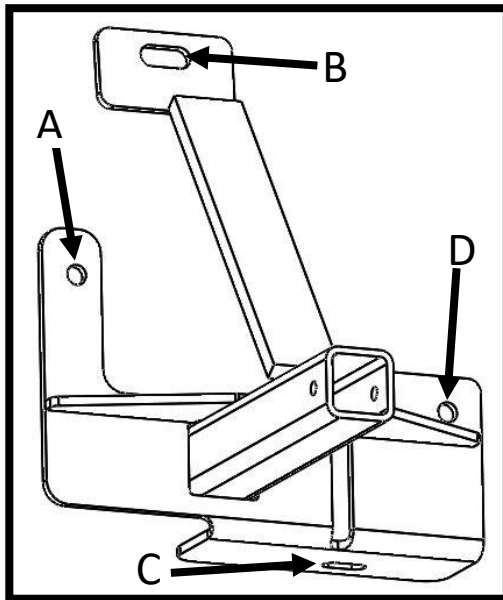
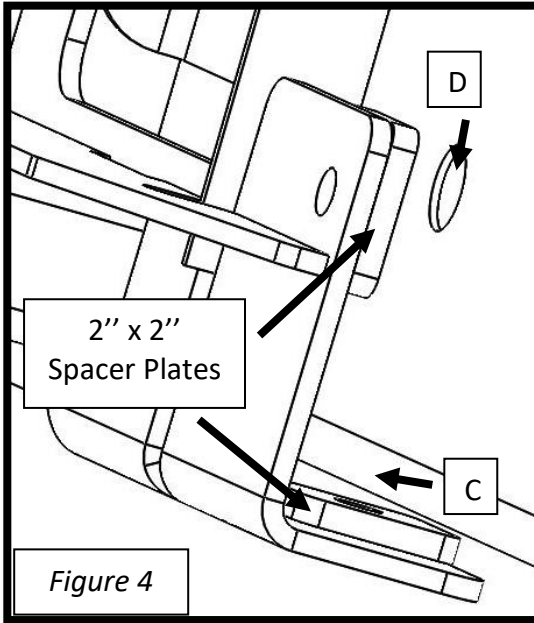

Figure 3

Step 4:

- Hold the Tie Down Receiver up against the frame, then make sure the 2" x 2" Plate Washers are in place as shown in Figure 4.



- Gently tug on the bolt fishers until the bolts in Hole A, Hole C, and Hole D protrude out of the frame and through the Tie Down Receiver. For the next step, it may be helpful to have someone else hold the Tie Down Receiver in place.
- Starting with Hole C, carefully remove the bolt fisher from the bolt, then loosely secure the 1/2"-13 x 2-1/2" Grade 5 Bolt with one 1/2" USS Flat Washer, one 1/2" Lock Washer, and one 1/2"-13 Grade 5 Hex Nut.
- Repeat the process for the bolts in Hole A and Hole D.

Step 5:

From the back side of the frame, insert one 1/2"-13 x 2" Grade 5 Hex Bolt through one 1/2" Star Washer, one 1"x2" Plate Washer, the bed support bracket, and through the Tie Down Receiver. Secure the bolt with one 1/2" USS Flat Washer, one 1/2" Lock Washer, and one 1/2"-13 Hex Nut. See Figure 5.

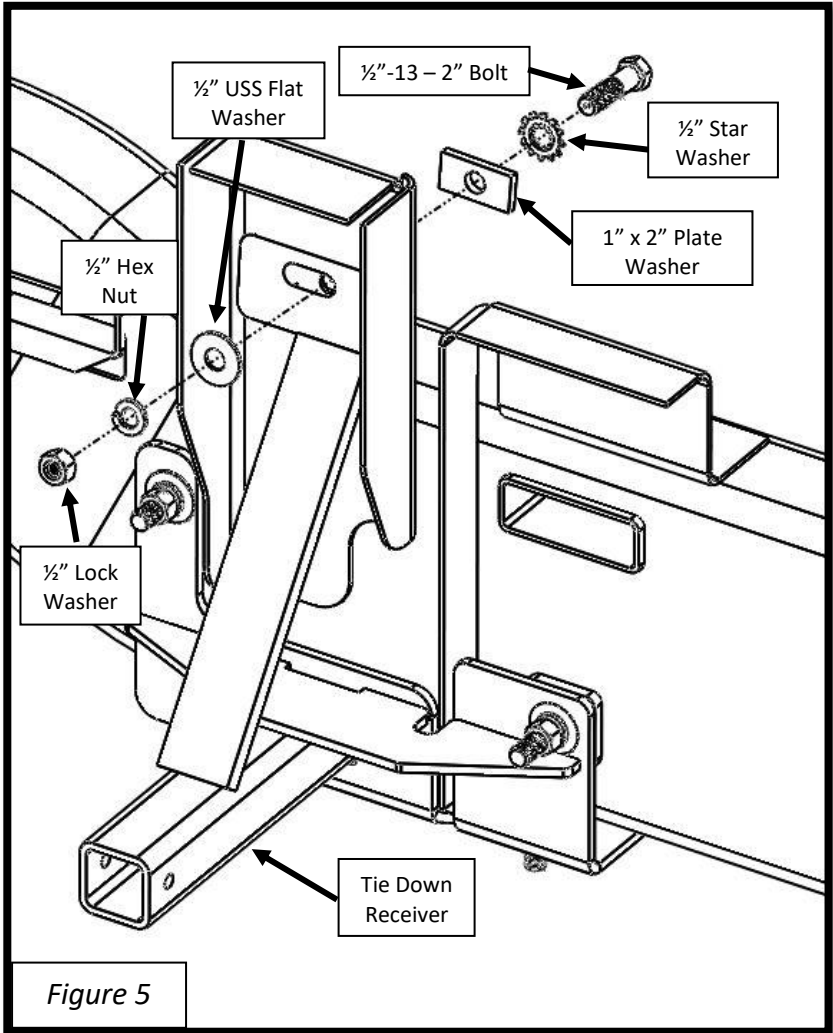

Step 6:

Torque all four bolts to 65 ft-lbs. Finished Installation shown in Figure 6.

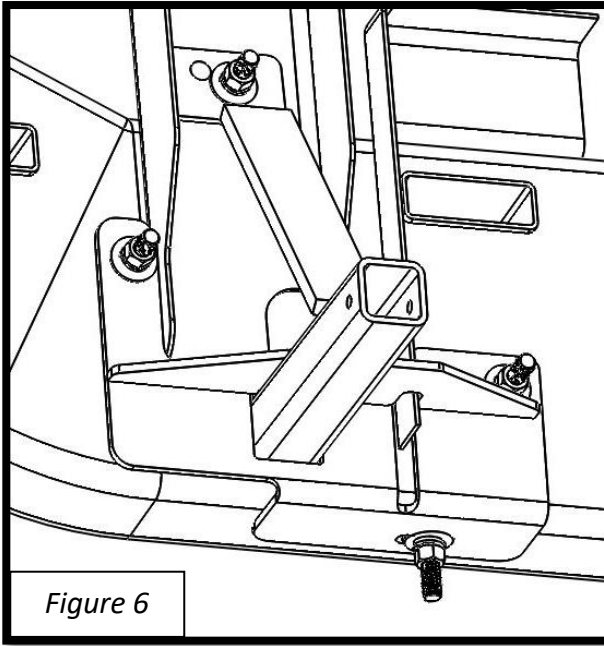

Repeat the process for the driver side of the vehicle.

TIEDOWN INSERT INSTALLATION INSTRUCTIONS

On one end of each of your tie down inserts is a triangular plate referred to by Torklift as a bullet plate. In most cases, the tie down inserts should be installed with the shorter side of the bullet plate facing away from each other (The shorter side of the front insert should point to the front of the truck and the shorter side of the rear insert should point towards the rear of the truck).



DRIVERS SIDE FRONT



DRIVERS SIDE REAR

Once installed, attach the TorkLift directional stickers to the face of the bullet plate on the insert as a reminder.

IMPORTANT NOTE: *Your tie down inserts are designed to have clearance inside of the receiver. This is to account for road debris, as well as aid in installation and removal. Some rattle may be expected if the inserts are left installed while not under load from the camper.*

Torklift International Limited Lifetime Warranty Information

322 Railroad Ave North, Kent, WA 98032

Torklift will require proof of purchase to register, with pictures of any defective product before issuing a replacement. Torklift will not register any product without proof of purchase, which can be faxed, scanned, emailed, or mailed to the information provided below. Torklift warrants its hitches, custom hitch receivers, frame mounted tie downs, turnbuckles, and accessories (excluding wire harnesses which carry a 90 day warranty) from date of purchase against defects in material and workmanship under normal use and service for the ownership life of the original consumer purchaser. All plastic, rubber, and/ or electrical components maintain a warranty of up to one year from the date of the purchase. **ALL COMMERCIAL APPLICATIONS ARE WARRANTED FOR A PERIOD OF 90 DAYS FROM THE DATE OF INSTALLATION/SERVICE.** Torklift will replace **FREE OF CHARGE** any part which proves defective in material or workmanship when presented to Torklift, **TRANSPORTATION CHARGES PREPAID** by purchaser, at the address above. **THIS WARRANTY IS LIMITED TO DEFECTIVE PARTS REPLACEMENT ONLY. LABOR CHARGES AND/OR DAMAGE INCURRED IN INSTALLATION OR REPLACEMENT, AS WELL AS INCIDENTAL AND CONSEQUENTIAL DAMAGES CONNECTED THEREWITH ARE EXCLUDED.** This warranty does not include the finish or paint on our products. Rusting, cracking or peeling of the finish is also excluded. Some states do not allow the exclusion or limitation of incidental or consequential damages, so the above limitation or exclusion may not apply to you. Any damage to Torklift products as a result of misuse, abuse, neglect, accident, improper installation or any use violative of instructions furnished by Torklift or **WHEN USED IN ANY COMMERCIAL APPLICATION WILL VOID THE WARRANTY.** This warranty gives you specific legal rights, and you may also have rights which vary from state to state. With warranty service, you may be able to go to a small claims court, a state court or a federal district court.



TORKLIFT™

INTERNATIONAL

322 Railroad Ave North, Kent, WA 98032

Phone (800) 246-8132 Fax (253) 854-8003

Or visit our website: www.TorkLift.com

Dear Valued Customer,

Thank you for making TorkLift your choice for truck, camper packages and accessories for your vehicle. By choosing TorkLift products, you have chosen a company that has been serving the RV industry for nearly 40 years and whose name has become synonymous with strength, quality and advanced design and installation.

Please take a few moments of your time to complete the Product Registration Warranty Card on the next page. When registering your newly purchased TorkLift products, you can be assured that your contact information is secure and that you and your product are getting the attention and respect that you deserve.

Thank you again for choosing TorkLift quality products.

**Register for your lifetime warranty and receive a free
Torklift International gift.**

To Fax: Send copies of the questionnaire, warranty card and receipt to
253-854-8003

To E-mail: Send copies of the questionnaire, warranty card and receipt to
warranty@torklift.com

To Mail: Send to Torklift International 1901 Fryar Ave Sumner, Wa 98390



OFFICIAL WARRANTY REGISTRATION CARD

322 Railroad Ave North, Kent, WA 98032

PLEASE FILL OUT THIS FORM COMPLETELY AND RETURN TO TORKLIFT WITHIN
30 DAYS OF PURCHASE ACCOMPANIED BY A COPY OF YOUR ORIGINAL RECEIPT

1. PART(S) PURCHASED

TODAY'S DATE: _____

PART #: _____ PART #: _____

PART #: _____ PART #: _____

PART #: _____ PART #: _____

2. PURCHASER INFORMATION

NAME: _____

ADDRESS: _____

CITY: _____ STATE: _____ ZIP / POSTAL CODE: _____

PHONE: (____) _____ - _____ EMAIL: _____

3. TRUCK INFORMATION

YEAR: _____ MAKE: _____

MODEL: _____ BED LENGTH: _____

4. CAMPER INFORMATION

YEAR: _____ MAKE: _____ MODEL: _____

5. DEALER INFORMATION

PURCHASED FROM: _____

ADDRESS: _____

CITY: _____ STATE: _____ ZIP / POSTAL: _____

INSTALLED BY: _____ OWNER ABOVE DEALER ANOTHER DEALER

IF ANOTHER DEALER, WHO: _____