

TORKLIFT INTERNATIONAL

OVER 35 YEARS OF INNOVATION, QUALITY, SAFETY.
IMPORTANT OWNER-OPERATOR INSTALLATION INSTRUCTIONS

F2022

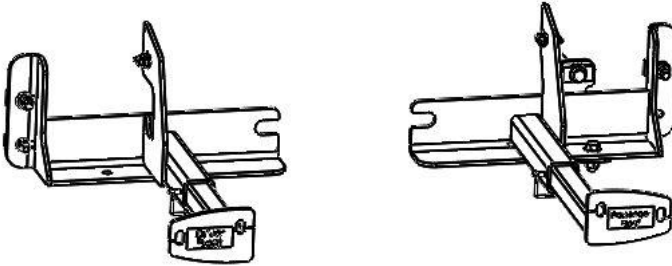

Version Number: 02, Date: 12/13/2016 By: RS

TECH SUPPORT (800) 246-8132

**AFTER INSTALL, PLEASE GIVE
THIS BOOKLET TO YOUR CUSTOMER**

Warnings

Truck Bed and Camper Protection

Torklift **does not** recommend installing your camper on top of a plastic bed liner (or other compressible material such as foam). These materials can act as a spring, causing increased vertical truck camper movement independent of the vehicle. Plastic bed liners can slide on the truck bed surface, and the truck camper can slide on top of the bed liner. Using a plastic bed liner or similar compressible material will void your warranty and may additionally cause truck bed and/or camper damage.









Minor movement or settling can occur in some incidental harsh driving conditions (on or off-road). A rubber bed mat is recommended to protect the truck bed and camper, but is not a requirement to maintain the Torklift legendary lifetime warranty.

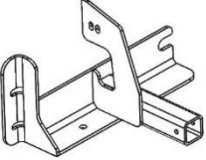
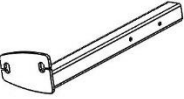
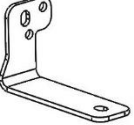
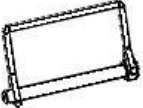









Suspension

To significantly reduce body roll, sag and sway Torklift strongly recommends the StableLoad. Torklift International StableLoads improve safety, handling, and to help level your truck. More information can be found at (www.Torklift.com/stableload).

If your truck is additionally equipped with suspension air bags Torklift cautions against over pressurization as this may lead to unsafe vehicle handling characteristics. We have found that airbags used in conjunction with StableLoads have allowed operators to lower air bag pressure by 50% or more. Only pressurize suspension air bags enough to level the truck.

Parts Inventory

Item Image	Item Description	Quantity
	Tie Down Receiver (Driver Side Shown)	2
	17 7/8" Straight Tie Down Insert (Driver Side Shown)	2
	Passenger Support Strap	1
	Bail Pin	2
	5/16"-18 x 1-1/4" GR 5 Bolt	4
	5/16" SAE Flat Washer	8
	5/16"-18 GR 5 Nut	4
	5/16" Lock Washer	4
	3/8"-16 x 1-3/4" Gr 5 Bolt	1
	3/8"-16 Gr 5 Nut	1
	3/8" SS flat Washer	2

	3/8" Lock Washer	1
	3/8" Star Washer	1
	1/2"-13 x 1-1/2" Gr 5 Bolt	1
	1/2"-13 x 2" Gr 8 Bolt	3
	1/2"-13 Gr 8 Nut	4
	1/2" SAE Flat Washer	5
	1/2" Lock Washer	4
	1/2" Star Washer	3
	1" x 2" Plate Washer	4
	1/2" Bolt Fisher	1
	3/8" Bolt Fisher	1

Installation Notes:

Step 1:

Begin by chocking the tires. Loosen the forward leaf spring hanger nut on each side of the truck as shown in Figure 1.1. The bolt is extremely tight; it may be necessary to use an impact gun or have a qualified shop loosen the nuts. Use a hammer to lightly tap the bolt out 1/2" on the passenger side. On the driver side remove the nut.

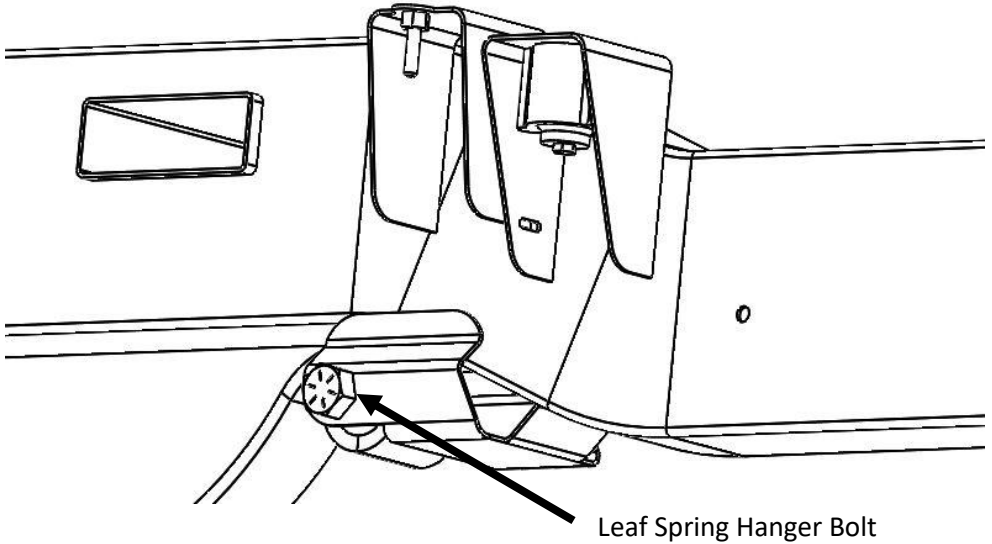

Figure 1.1

Step 2:

Begin the passenger side by removing the exhaust hanger bracket shown in figure 2.1 leaving the clip-on nuts in place. Fish one 1/2"-13 x 2" Hex Head Bolt, one 1" x 2" Plate Washer and a one 1/2" Star Washer (see Figure 2.2) into Hole A and exiting out of Hole B as shown in Figure 2.3.

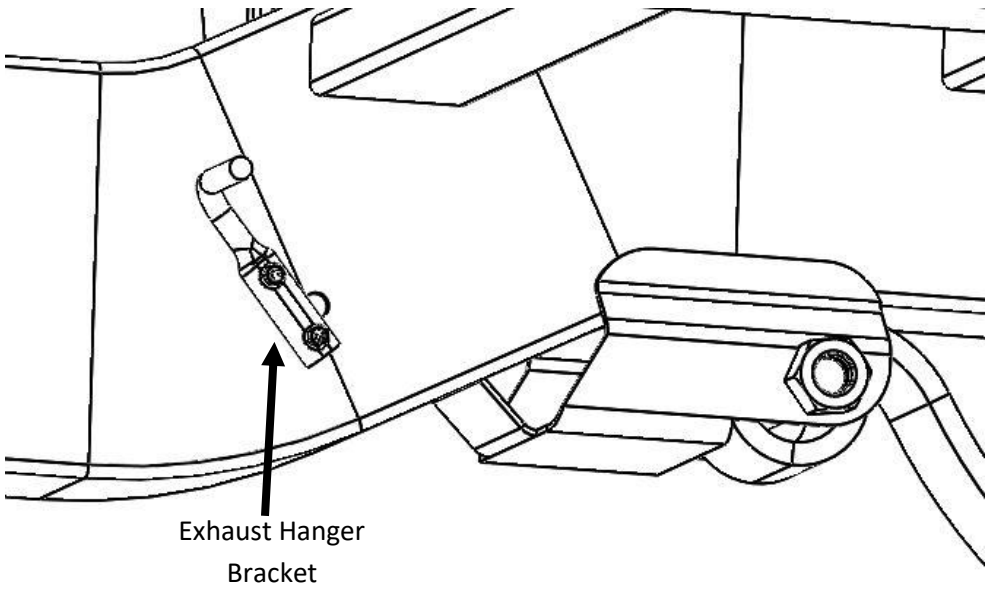

Figure 2.1 (Exhaust not shown for clarity)

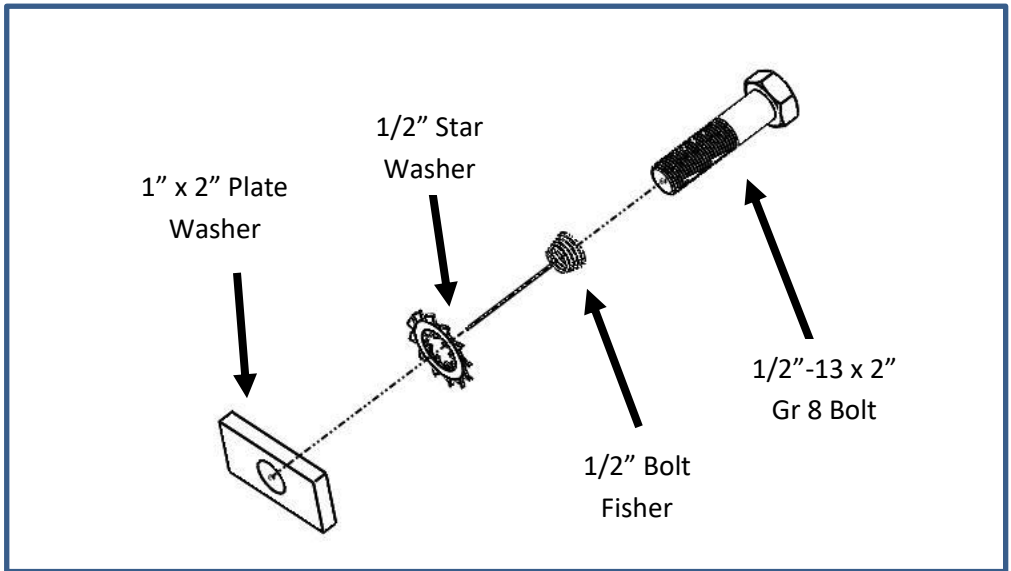

Figure 2.2

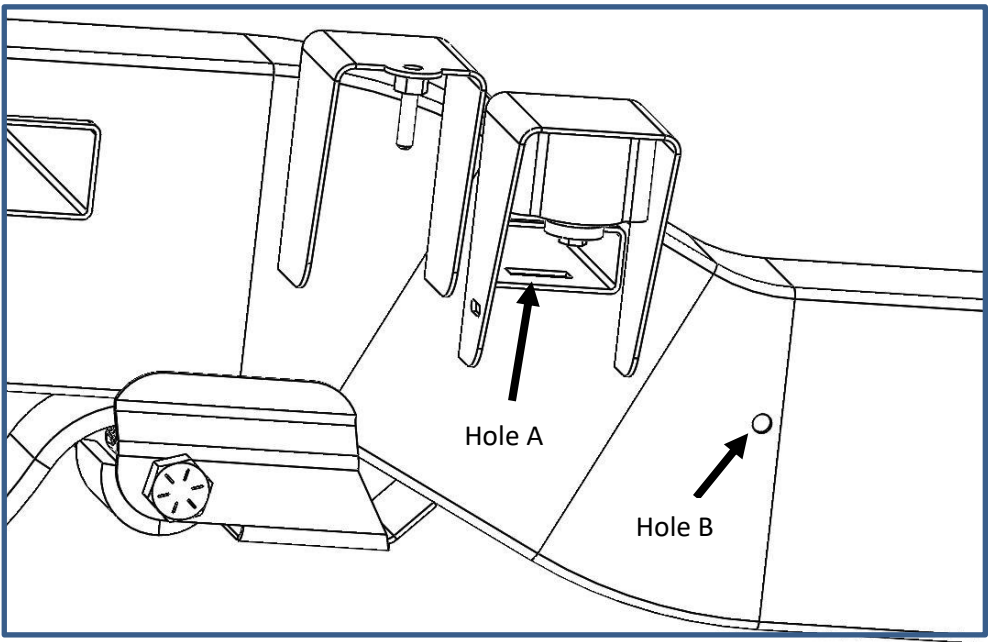

Figure 2.3 – Outside of Frame (Bed not shown for clarity)

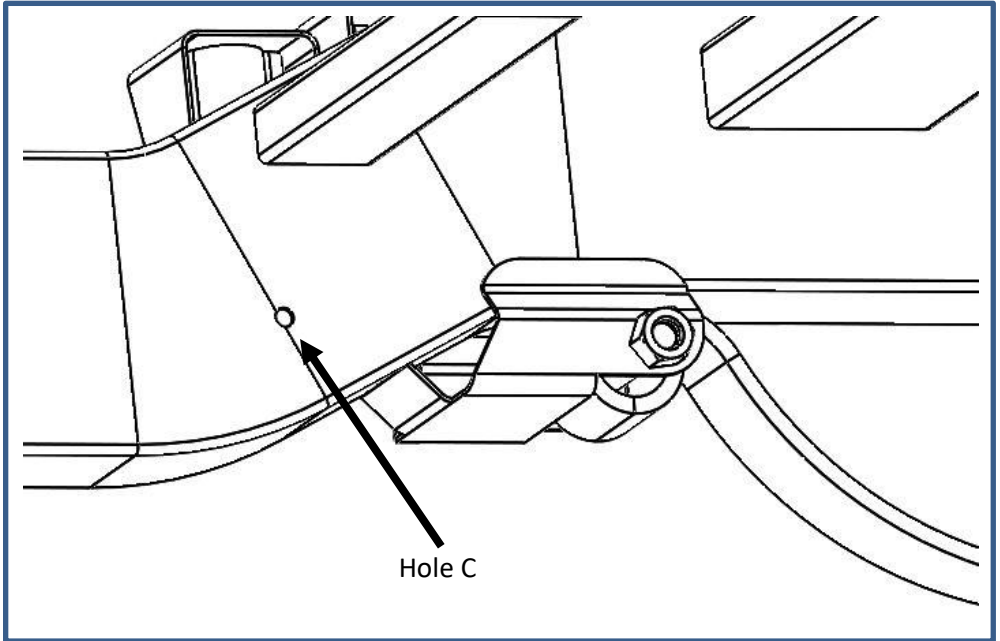

Figure 2.3 – Inside of Frame.

Step 3:

Slide the Tie Down Receiver behind the Leaf Spring Bolt Head. Position the Tie Down to line up with the Bolt in Hole B as shown in Figure 2.2. Secure the bolt with one 1/2" Flat Washer, one 1/2" Lock washer, and one 1/2-13 Gr 8 Nut as shown in Figure 3.1.

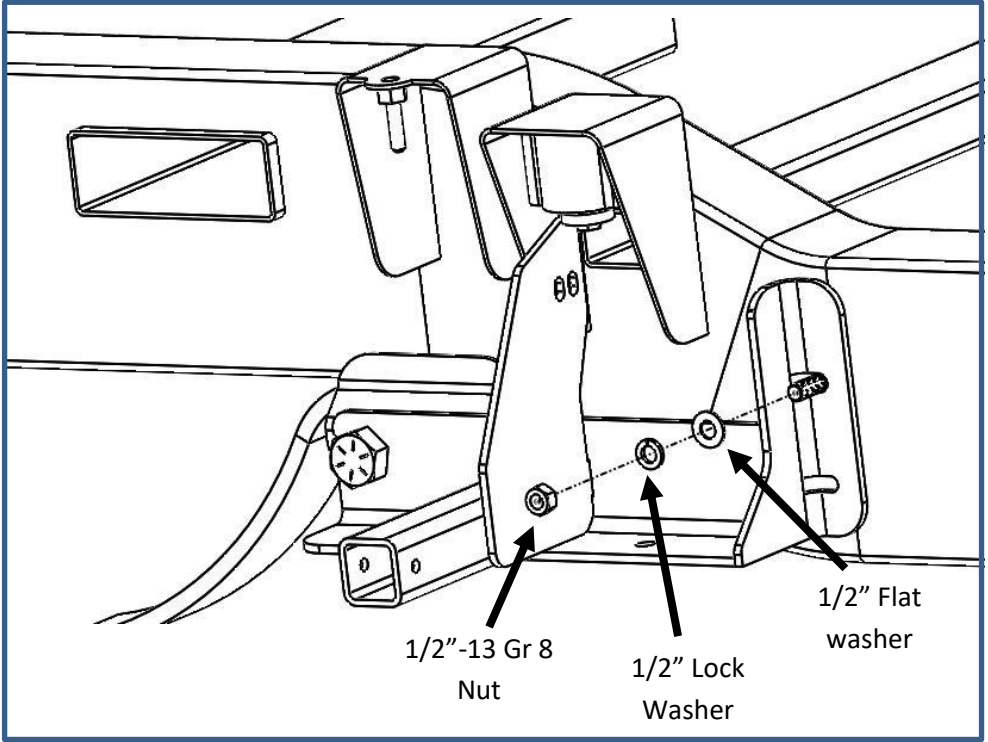

Figure 3.1

Step 4:

Insert two 5/16"-18 x 1-1/4" Gr 5 Bolts with one 5/16" SAE Flat Washer each through the slot and vertical gusset as shown in figure 4.1. Secure each bolt with one 5/16" SAE Flat Washer, one 5/16" Lock Washer and one 5/16"-18 Gr 5 Nut.

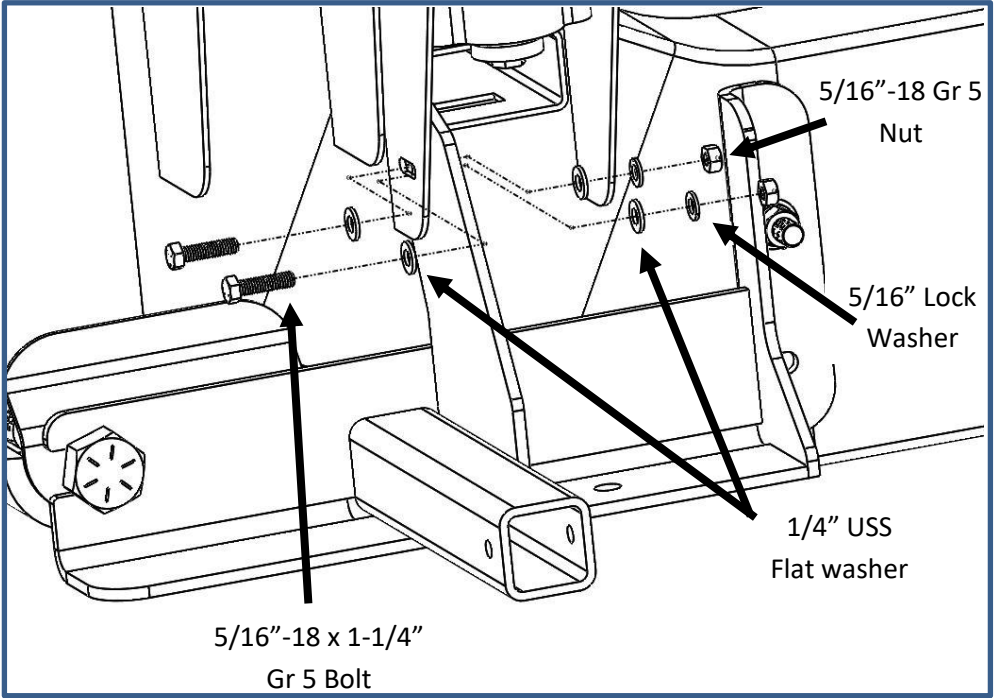

Figure 4.1

Step 5:

Fish one 1/2"-13 x 2" bolt with one 1" x 2" Plate Washer and one 1/2" Star Washer into Hole A and exiting out of Hole C. See Figure 2.1 and Figure 2.3. Place the Passenger Support Strap over the bolt and secure it with one 1/2" Flat Washer, one 1/2" Lock Washer and one 1/2"-13 Gr 8 Nut as Shown in Figure 5.1.

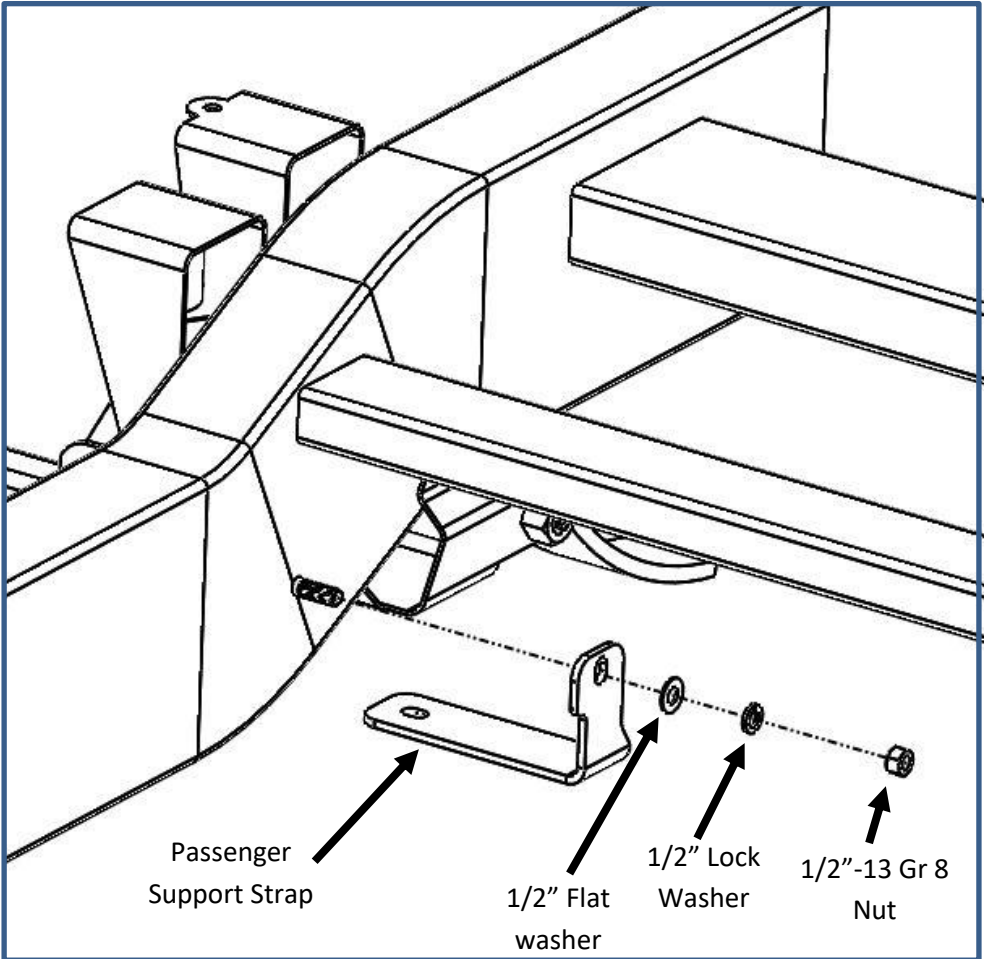

Figure 5.1 – Inside of Frame

Step 6:

Line up the Passenger Support Strap with the Tie Down Receiver hole, then secure it using one 1/2"-13 x 1-1/2" Gr 5 Bolt, two 1/2" Flat Washers, one 1/2" Lock Washer and one 1/2"-13 Gr 8 Nut. See figure 6.1.

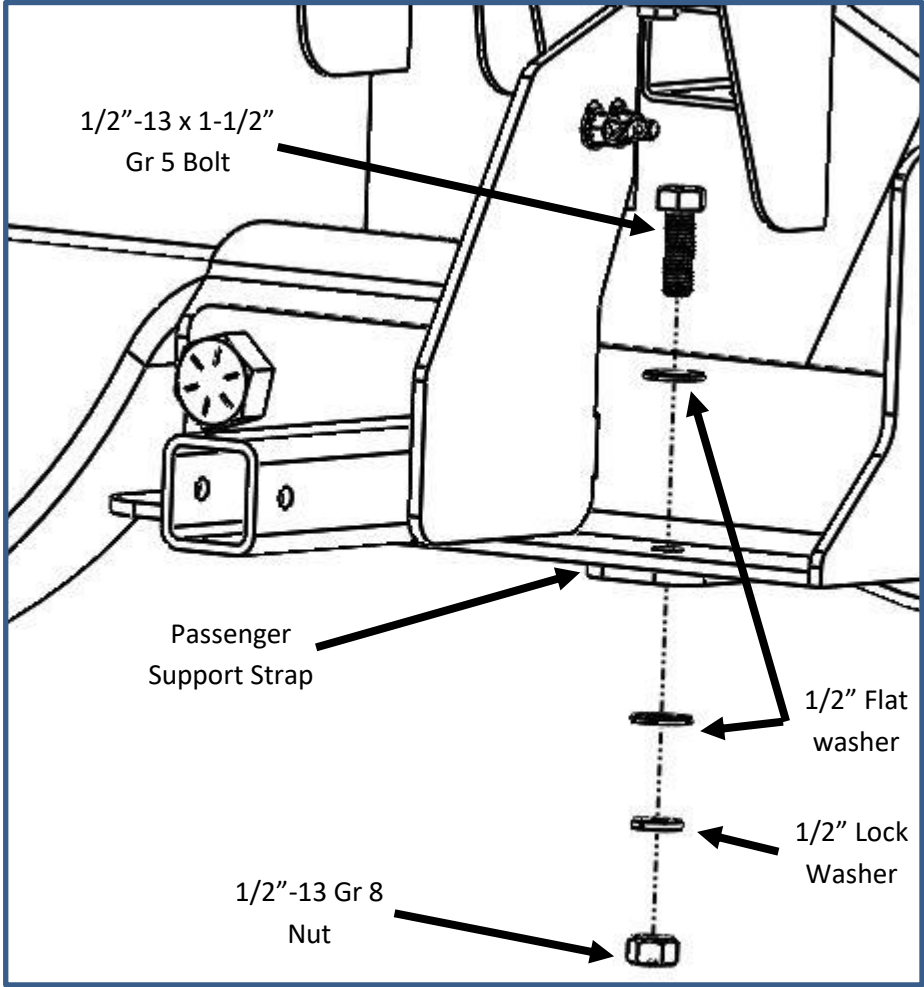

Figure 6.1

Step 7:

Reinstall the exhaust hanger bracket over the Passenger Support Strap using the factory hardware as shown in Figure 7.1.

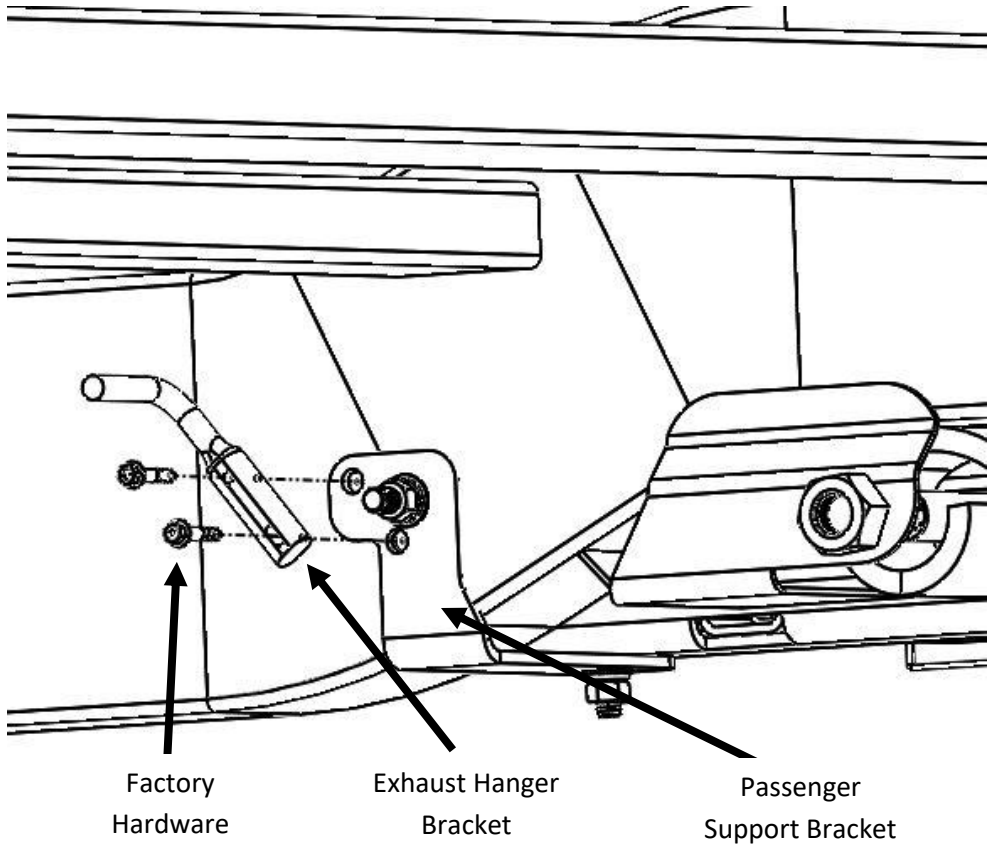

Figure 7.1(Exhaust not shown for clarity)

Step 8:

Remove the E-Brake Cable Bracket as shown in Figure 8.1 on the driver side of the vehicle. Fish one 1/2"-13 x 2" bolt, one 1" x 2" Plate Washer and one 1/2" Star Washer into Hole D and exiting out of Hole E. See Figure 2.1 and Figure 8.3. Next, fish one 3/8"-16 x 1-3/4" Gr 5 Bolt, one 3/8" Flat Washer, one 1" x 2" Plate Washer and one 3/8" Star washer using the 3/8" Bolt Fisher into Hole D and out of Hole F as shown in Figure 8.2.

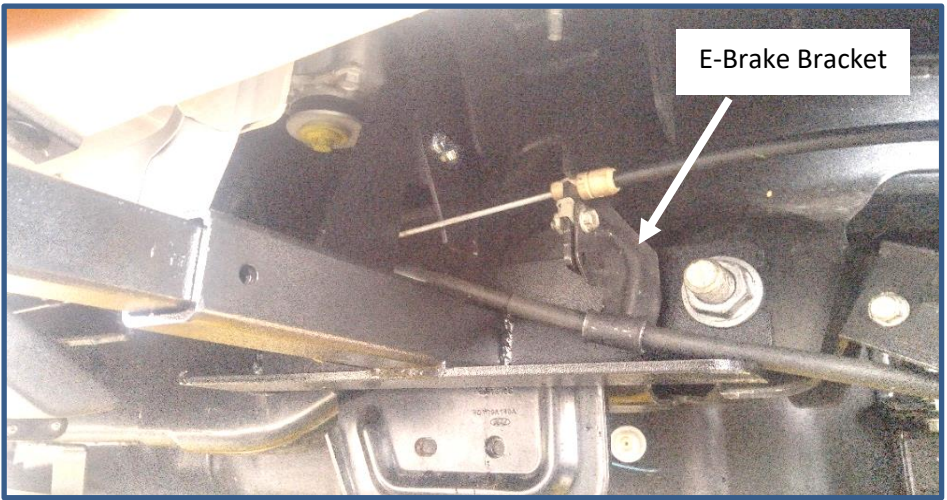

Figure 8.1

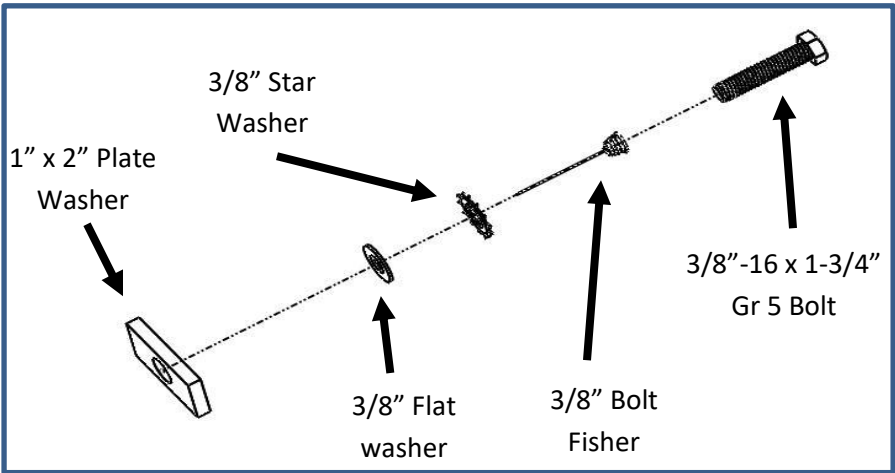

Figure 8.2

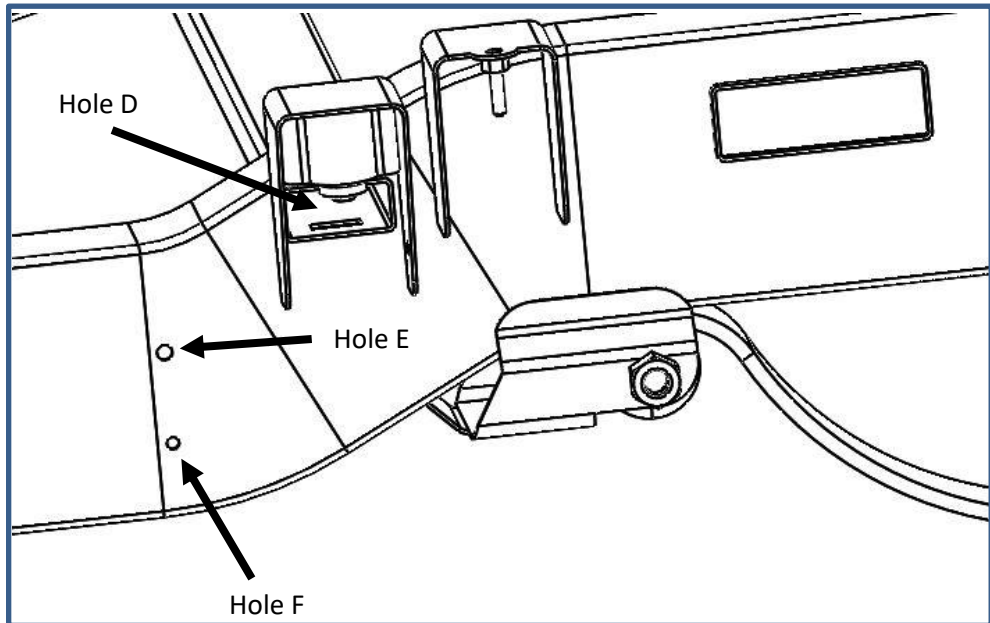

Figure 8.3

Step 9:

Slide the Driver Side Tie Down Receiver over the Bolt and position it to line up with the Bolts in Hole E and F. Assemble the hardware as shown in Figure 9.1.

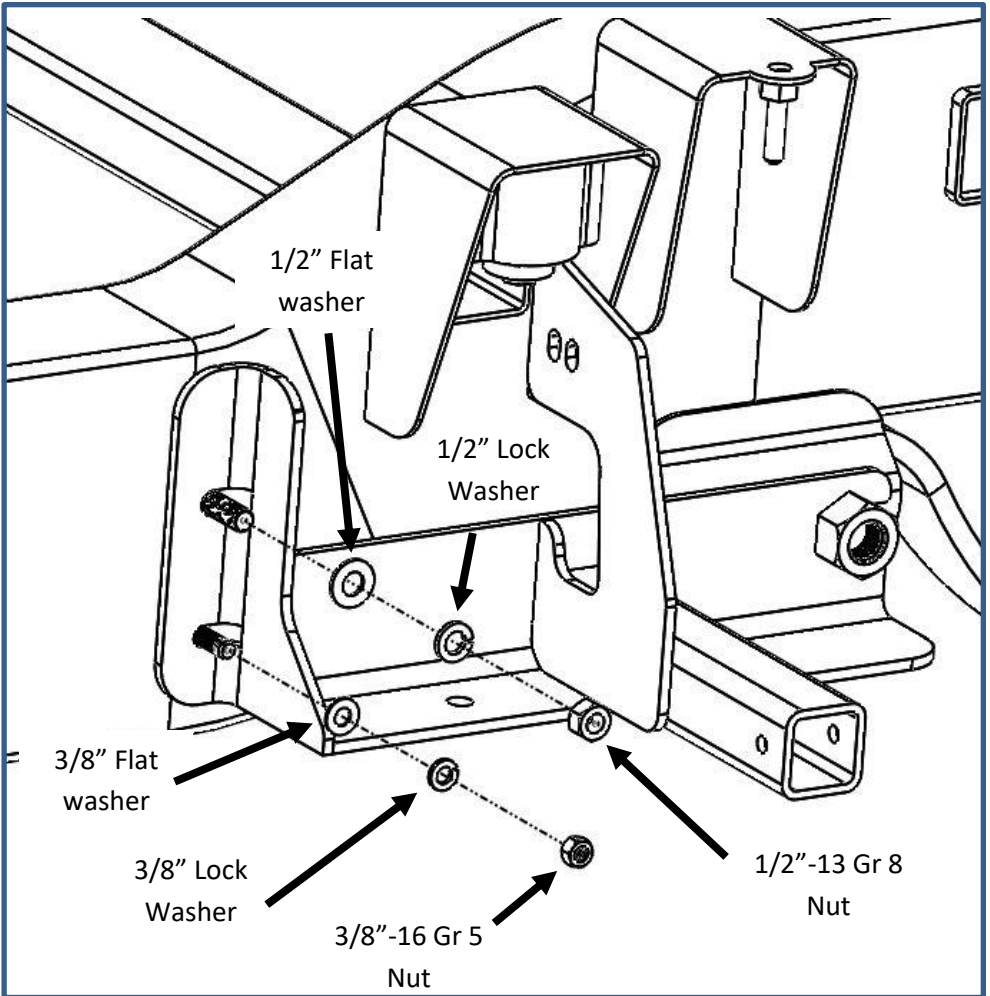

Figure 9.1

Step 10:

Install The 5/16" hardware on the driver's side vertical support gusset as shown in Step 4.

Step 11:

Reinstall the E-Brake bracket in the stock location. Torque all Grade 8 1/2" Hardware to 75 ft-lbs, Grade 5 1/2" Hardware to 60 ft-lbs, 3/8" hardware to 30 ft-lb and 5/16" hardware to 18 ft-lbs. Reinstall the leaf spring hanger nuts and torque to 200 ft-lbs.

TIEDOWN INSERT INSTALLATION INSTRUCTIONS

On one end of each of your tie down inserts is a triangular plate referred to by Torklift as a bullet plate. In most cases, the tie down inserts should be installed with the shorter side of the bullet plate facing away from each other (The shorter side of the front insert should point to the front of the truck and the shorter side of the rear insert should point towards the rear of the truck).



DRIVERS SIDE FRONT



DRIVERS SIDE REAR

Once installed, attach the TorkLift directional stickers to the face of the bullet plate on the insert as a reminder.

IMPORTANT NOTE: *Your tie down inserts are designed to have clearance inside of the receiver. This is to account for road debris, as well as aid in installation and removal. Some rattle may be expected if the inserts are left installed while not under load from the camper.*

Torklift International Limited Lifetime Warranty Information

322 Railroad Ave North, Kent, WA 98032

Torklift will require proof of purchase to register, with pictures of any defective product before issuing a replacement. Torklift will not register any product without proof of purchase, which can be faxed, scanned, emailed, or mailed to the information provided below. Torklift warrants its hitches, custom hitch receivers, frame mounted tie downs, turnbuckles, and accessories (excluding wire harnesses which carry a 90 day warranty) from date of purchase against defects in material and workmanship under normal use and service for the ownership life of the original consumer purchaser. All plastic, rubber, and/ or electrical components maintain a warranty of up to one year from the date of the purchase. **ALL COMMERCIAL APPLICATIONS ARE WARRANTED FOR A PERIOD OF 90 DAYS FROM THE DATE OF INSTALLATION/SERVICE.** Torklift will replace **FREE OF CHARGE** any part which proves defective in material or workmanship when presented to Torklift, **TRANSPORTATION CHARGES PREPAID** by purchaser, at the address above. **THIS WARRANTY IS LIMITED TO DEFECTIVE PARTS REPLACEMENT ONLY. LABOR CHARGES AND/OR DAMAGE INCURRED IN INSTALLATION OR REPLACEMENT, AS WELL AS INCIDENTAL AND CONSEQUENTIAL DAMAGES CONNECTED THEREWITH ARE EXCLUDED.** This warranty does not include the finish or paint on our products. Rusting, cracking or peeling of the finish is also excluded. Some states do not allow the exclusion or limitation of incidental or consequential damages, so the above limitation or exclusion may not apply to you. Any damage to Torklift products as a result of misuse, abuse, neglect, accident, improper installation or any use violation of instructions furnished by Torklift or **WHEN USED IN ANY COMMERCIAL APPLICATION WILL VOID THE WARRANTY.** This warranty gives you specific legal rights, and you may also have rights which vary from state to state. With warranty service, you may be able to go to a small claims court, a state court or a federal district court.



TORKLIFT™

INTERNATIONAL

322 Railroad Ave North, Kent, WA 98032

Phone (800) 246-8132 Fax (253) 854-8003

Or visit our website: www.TorkLift.com

Dear Valued Customer,

Thank you for making TorkLift your choice for truck, camper packages and accessories for your vehicle. By choosing TorkLift products, you have chosen a company that has been serving the RV industry for nearly 40 years and whose name has become synonymous with strength, quality and advanced design and installation.

Please take a few moments of your time to complete the Product Registration Warranty Card on the next page. When registering your newly purchased TorkLift products, you can be assured that your contact information is secure and that you and your product are getting the attention and respect that you deserve.

Thank you again for choosing TorkLift quality products.

Register for your lifetime warranty and receive a free Torklift International gift.

To Fax: Send copies of the questionnaire, warranty card and receipt to
253-854-8003

To E-mail: Send copies of the questionnaire, warranty card and receipt to
warranty@torklift.com

To Mail: Send to Torklift International 322 Railroad Ave North, Kent, WA 98032



OFFICIAL WARRANTY REGISTRATION CARD

322 Railroad Ave North, Kent, Wa 98032

Please fill out this form completely and return to Torklift within 30 days of purchase accompanied by a copy of your original receipt

1. PART(S) PURCHASED

TODAY'S DATE: _____

PART#: _____ PART#: _____

PART#: _____ PART#: _____

PART#: _____ PART#: _____

2. PURCHASER INFORMATION

NAME: _____

ADDRESS: _____

CITY: _____ STATE: _____ ZIP / POSTAL CODE: _____

PHONE: (____) _____ - _____ EMAIL: _____

3. TRUCK INFORMATION

YEAR: _____ MAKE: _____

MODEL: _____ BED LENGTH: _____

4. CAMPER INFORMATION

YEAR: _____ MAKE: _____ MODEL: _____

5. DEALER INFORMATION

PURCHASED FROM: _____

ADDRESS: _____

CITY: _____ STATE: _____ ZIP / POSTAL: _____

INSTALLED BY: _____ OWNER ABOVE DEALER ANOTHER DEALER

IF ANOTHER DEALER, WHO: _____