

GATORBACK

1994 - 2002, Dodge Ram Rear Mount Bracket Mounting Diagram & Instructions 755005

IMPORTANT:

The manufacturer is not responsible for negligent use of vehicle with mud flaps installed, including over-tightening of screws and bolts causing damage to vehicle or mud flaps.

TOOLS REQUIRED

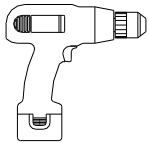

1/2" or 3/8" drill



#2 Phillips screwdriver

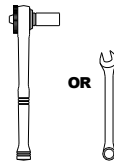

5/16" wrench or
socket wrench



1/4" drill bit

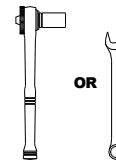

3/8" wrench or
socket wrench

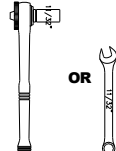

11/32" wrench or
socket wrench

KIT CONTAINS: PARTS BAG #755135

a) (1) Mount Bracket,
Rear, LH
Part #755107



b) (1) Mount Bracket
Rear, RH
Part #755108



c) (6) Machine Screw
#8-32 x 7/8"
Part #012025



d) (6) Flat Washer
0.188" x 0.781"
Part #018018



e) (6) Nylock Nut
#8-32
Part #025005



f) (4) Machine Screw
#10-24 x 1"
Part #012022



g) (4) Hex Nut
#10-24
Part #025003



h) (4) Lock Washer
#10
Part #024001



i) (4) Flat Washer
0.203" x 1"
Part #018031



j) (4) Half Washer
0.203" x 1"
Part #018032



INSTALLATION

For ease of installation, it is suggested that the wheel be removed.

- Fasten the LH mount bracket to the left hand flap with 3 machine screws / small washers and nylock nuts to Holes #1, #2 and #3 or if you prefer the flap mounted higher and farther away from the ground then use Holes #4, #5 and #6. See Diagram #1.

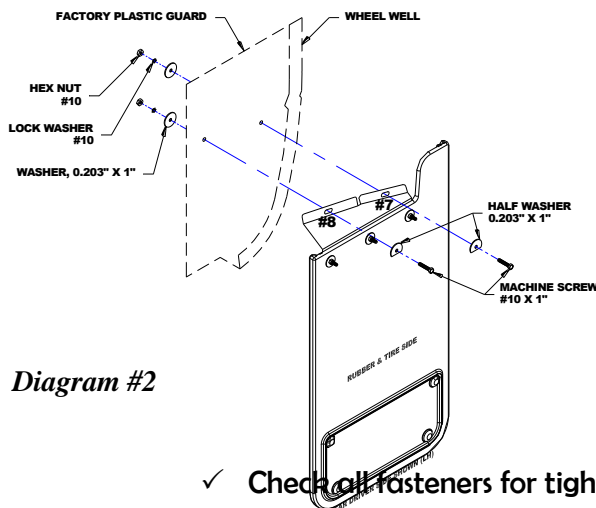
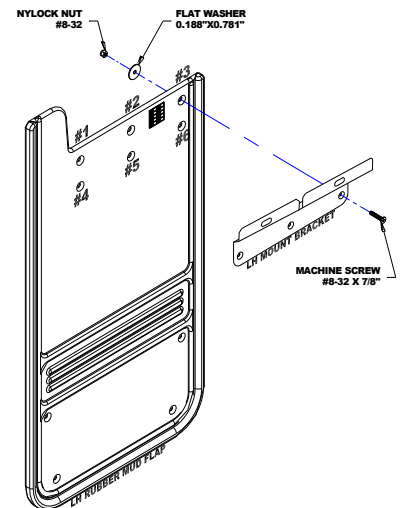

Diagram #2

✓ Check all fasteners for tightness. Repeat procedure on the passenger side.

Diagram #1



- Drill a 1/4" hole (2 places) through the bracket Holes #7 and #8 through the factory plastic guard and fasten the holes #7 and #8 with 2 machine screws / half washers/ flat washers / lock washers and hex nuts. See Diagram #2.