

# 2004 - C, Ford F-Series Rear Mount Bracket Mounting Diagram & Instructions 755006B

## GATORBACK

### IMPORTANT:

*The manufacturer is not responsible for negligent use of vehicle with mud flaps installed, including over-tightening of screws and bolts causing damage to vehicle or mud flaps.*

### TOOLS REQUIRED:



#2 Phillips screwdriver

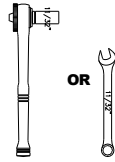



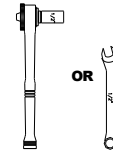





1 1/32" wrench or  
socket wrench



1/2" wrench or  
socket wrench

### KIT CONTAINS: PARTS BAG #755529

- a) (1) Mount Bracket, Rear, LH Part #755109 
- b) (1) Mount Bracket, Rear, RH Part #755110 
- c) (6) Machine Screw, SS #8-32 x 7/8" Part #012025 
- d) (6) Flat Washer 0.188" x 0.781" Part #018018 
- e) (6) Nylock Nut SS #8-32 Part #025005 
- f) (4) 3/8 Hex Nut PLTD Part # 025015 
- g) (4) Capscrew 3/8 Part # 014042 
- h) (10) Washer 3/8 Flat Part # 018049 
- i) (4) Lock Washer, 3/8" Helicoil Part # 24006 

### INSTALLATION

*For ease of installation, it is suggested that the wheel be removed.*

1. Fasten the LH mount bracket to the left hand flap with 3 machine screws / small washers and nylock nuts to Holes #1, #2 and #3 or if you prefer the flap mounted higher and farther away from the ground then use Holes #4, #5 and #6. See Diagram #1.

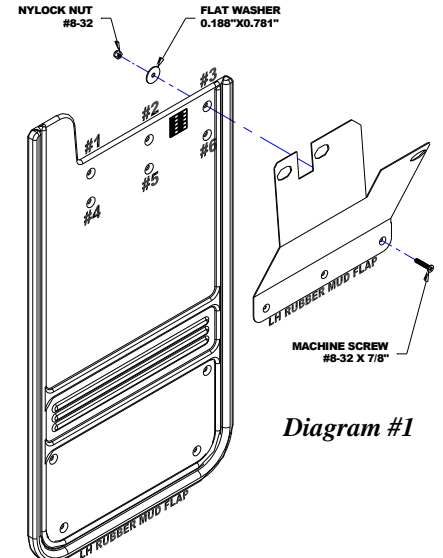

Diagram #1

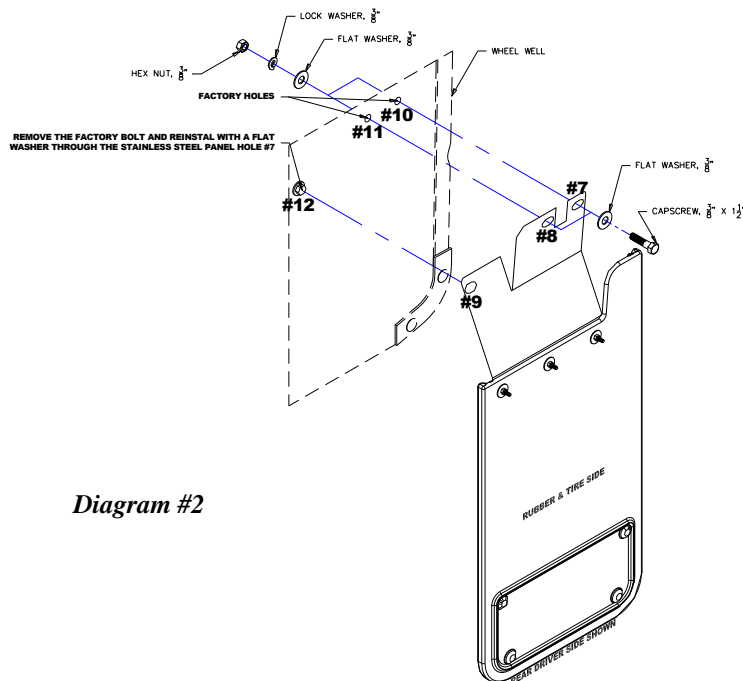

Diagram #2

2. Remove the 3 factory body bolts and rod bracket. Reinstall with the same orientation through the LH mount bracket Holes #7, #8 and #9 with the LH mount bracket facing the rear of the vehicle. Loosely secure at this point.
3. Loosely secure the upper part of the flap with two 3/8" capscrews, four 3/8" flat washers two 3/8" lock washers & two 3/8" hex nuts on holes #7 & #8 through the factory body holes #10 & #11. See Diagram #2

✓ Check all fasteners for tightness. Repeat procedure on the passenger side.