

GATORBACK

2002 – C, Dodge Ram Rear Mount Bracket Mounting Diagram & Instructions 755021

IMPORTANT:

The manufacturer is not responsible for negligent use of vehicle with mud flaps installed, including over-tightening of screws and bolts causing damage to vehicle or mud flaps.

TOOLS REQUIRED:

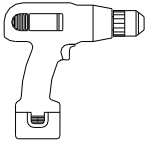

Electric or re-chargeable
1/2" or 3/8" drill.



#2 Phillips screwdriver



3/8" socket driver

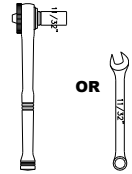

11/23" open end
wrench or socket wrench

KIT CONTAINS: PARTS BAG #755175

a) (2) Mount Bracket,
Rear
Part #755174



b) (6) Machine Screw
#8-32 x 7/8"
Part #012025



c) (6) Flat Washer
0.188" x 0.781"
Part #018018



d) (6) Nylock Nut
#8-32
Part #025005



e) (6) Tek Screw
1/4" X 1.25"
Part #010011



f) (6) Flat Washer
0.281" x 1"
Part #018028



INSTALLATION

For ease of installation, it is suggested that the wheel be removed.

1. Fasten the LH mount bracket to the left hand flap with 3 machine screws / small washers and nylock nuts to Holes #1, #2 and #3 or if you prefer the flap mounted higher and farther away from the ground then use Holes #4, #5 and #6.
See Diagram #1.

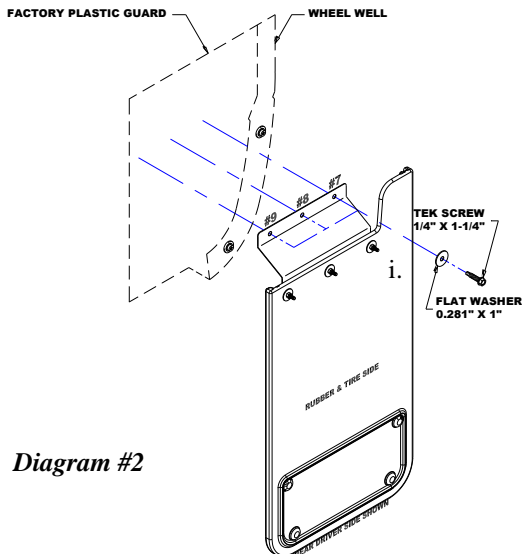
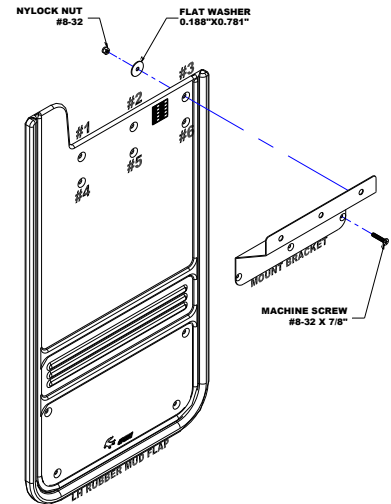

Diagram #2

Diagram #1



2. Secure the bracket on Holes #7, #8, and #9 through the factory plastic guard with 3 TEK screws and washers.
See Diagram #2.

✓ Check all fasteners for tightness. Repeat procedure on other side