

GATORBACK

2010-14, DODGE HD DUALY
REAR MUD FLAP SET
Mounting Diagram & Instructions
PART #756350/756667

IMPORTANT:

The manufacturer is not responsible for negligent use of vehicle with mud flaps installed, including over-tightening of screws and bolts causing damage to vehicle or mud flaps.

TOOLS REQUIRED



Electric or re-chargeable
1/2" or 3/8" drill.



1/4
drill bit

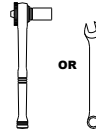

3/8" and 5/16" wrench
or socket set



3/8" Socket Drivers

SCREWS / FASTENERS / WASHERS / FLAPS - PARTS BAG # 755533

a) (1) Flap Assembly,
Rear, RH

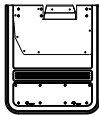

b) (1) Flap Assembly
Rear, LH

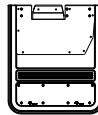

c) (6) Washers, Flat
0.281" x 1"
Part #018028



d) (18) Nut, Hex, SS
#10
Part #025003



e) (18) Lock Washer
#10
Part #024001



f) (36) Flat Washer
0.203 x 1" 18ga
Part #018031



g) (2) Machine Screw
#10 x 1.5"
Part #012027



h) (16) Screw Machine
#10 x 1"
Part #012022



i) (6) Screw Tek
1/4 x 1 1/4"
Part #010011



j) (1) Brkt, Z, DS
Part # 750433



k) (1) Brkt, Z, PS
Part # 750434



Prior to installation of your Mud Flap, see the above diagrams and parts list for all necessary parts. Start on the driver side.

INSTALLATION

For ease of installation, it is suggested that the wheel be removed.

1. Before you install your precision mud flap, see the diagram and parts list for all necessary parts. Start on the driver side.
2. Remove factory harness mounts A & B with harness and reinstall to the "Z" bracket holes C & D.
3. Bolt the upper holes of the "Z" bracket to the existing factory push screw holes A & B with two machine screws, four flat washers (0.203" x 1") two lock washers and two hex nuts.
4. Remove the factory screws #11 & #12 on the wheel flare as shown on the diagram and reinstall the two factory screws on holes #1 and #3 through the stainless steel mount into the factory holes #11 and #12, loosely secure at this point.
5. Square the flap with the tire and push the flap Up against the wheel flare then secure the flap with three tek screws and three flat washers (0.281" x 1") along the wheel flare as shown on the diagram. Now tighten the two factory screws on holes #1 & #3.

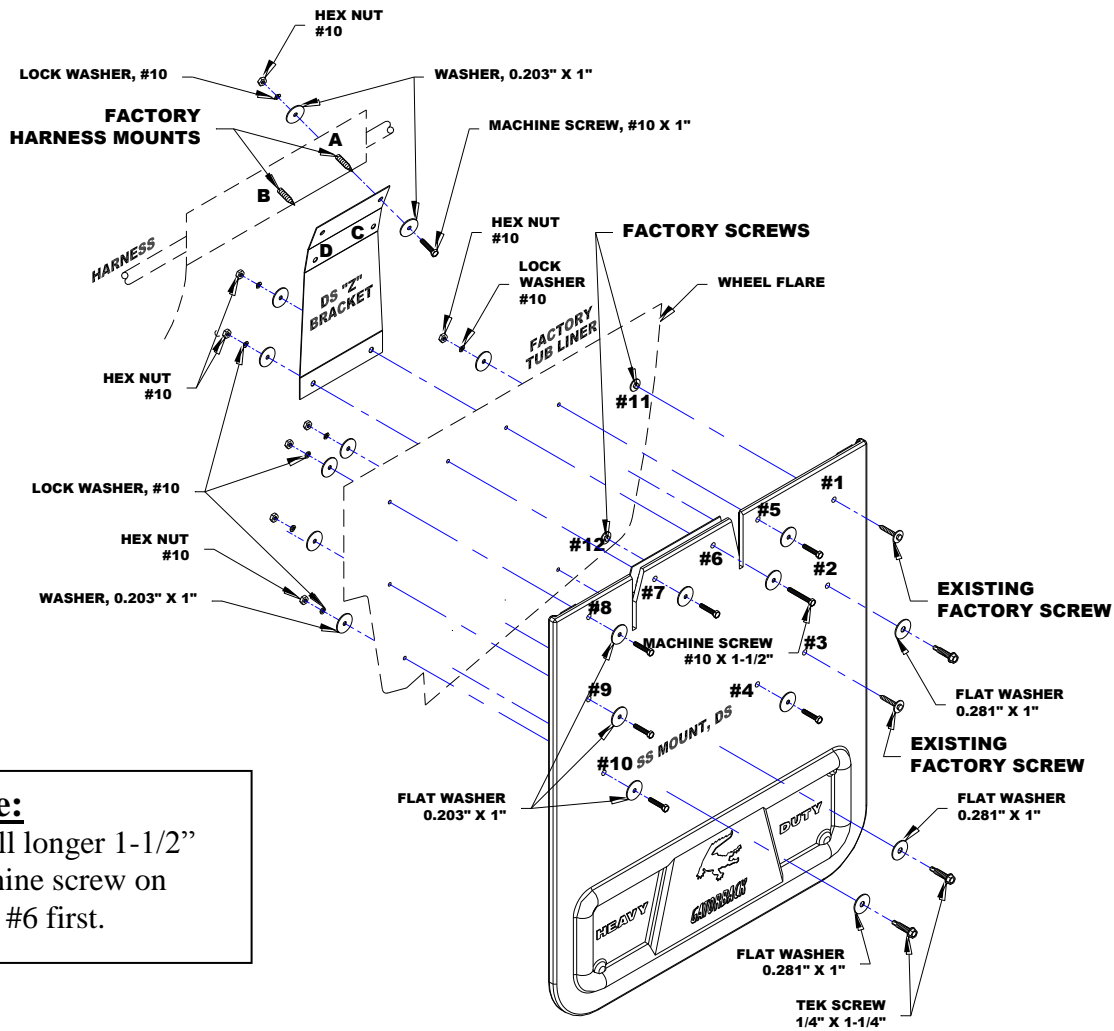

Note:
Install longer 1-1/2\"/>

5. Square the flap with the tire and push the flap Up against the wheel flare then secure the flap with three tek screws and three flat washers (0.281" x 1") along the wheel flare as shown on the diagram. Now tighten the two factory screws on holes #1 & #3.
6. Drill a 1/4" hole (7 places) from holes #4 to #10 through the factory tub liner then fasten holes #5 and #6 with two machine screws, the long screw used on hole #6, four flat washers (0.203 x 1"), two lock washers & two hex nuts and the remaining holes #3, #4 & #7 to #9 with five machine screws, ten flat washers (0.203" x 1"), five lock washers & five hex nuts.

✓ Check all fasteners for tightness. Repeat procedure on the passenger side

MAINTENANCE TIPS

Rubber Care

Maintaining your rubber mud flaps is the same as looking after your tires. Use soap and water to remove road dirt and debris and then clean rubber with any good rubber weather / wear protector that you would use on your tires. All Mud Flaps are made from new virgin rubber for long lasting great looks.

Stainless Steel Care

Keeping your mud flaps looking great requires proper care to be taken with your stainless steel - the same care that you would take to look after the paint on your truck. High amounts of salt will deteriorate even the finest stainless steel if it is continuously abused. Wash the stainless steel on your mud flaps from time to time to remove any road grime or salt. To shine, use window cleaner to remove any spots or streaks.