

GATORBACK

No-Drill System 2013-14, Dodge HD Dually

Rear Mount Bracket

No drilling into your vehicle fender required!

Mounting Diagram & Instructions

Part # 756886

IMPORTANT:

The manufacturer is not responsible for negligent use of vehicle with mud flaps installed, including over-tightening of screws and bolts causing damage to vehicle or mud flaps.

TOOLS REQUIRED:

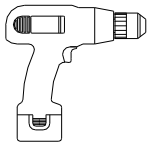

*Electric or Re-Chargeable
1/2" or 3/8" drill.*

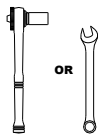

*1/2 Open End Wrench
or socket wrench*

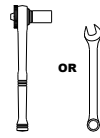

*9/16" Open End Wrench
or socket wrench*



3/8" Drill Bit



Tin Snips

KIT CONTAINS:

a) (2) Mud Flap Strip
Part #750595



b) (2) Pressure Plate
Part #750596

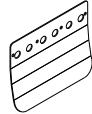

c) (1) Bracket
DS
Part#750597



d) (1) Bracket
PS
Part #750598



e) (1) Offset Bracket
DS
Part #750603

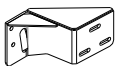

f) (1) Offset Bracket
PS
Part #750604

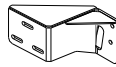

g) (14) Carriage Bolt
3/8"-16UNCx1-1/4"
Part #014026



h) (4) Washer Head Bolt
M8-1.25x30mm
Part #014013

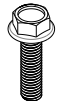

i) (16) Washer
Plated, Flat 3/8"
Part #018046



j) (4) Washer
Plated, Flat 5/16"
Part #018047



k) (4) Washer
Lock, 5/16"
Part #024002



l) (16) Washer
Plated, Lock 3/8"
Part #024006



m) (16) Hex Nut
Plated 3/8"-16UNC
Part #025015



n) (1) Clinch Nut Placing Tool
M8-1.25
Part #750608

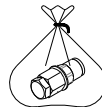

o) (2) T-Bolt Welded Assembly
Universal
Part #762236

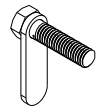

INSTALLATION

For ease of installation, it is suggested that the wheel be removed.

1. Before you install your Precision mud flap, see the diagram and parts list for all necessary parts. Start on driver's side.
2. Cut off a piece of liner approximately 6" x 11" (See diagram #1).
3. Drill four holes on the optional mud flap (See diagram #2).

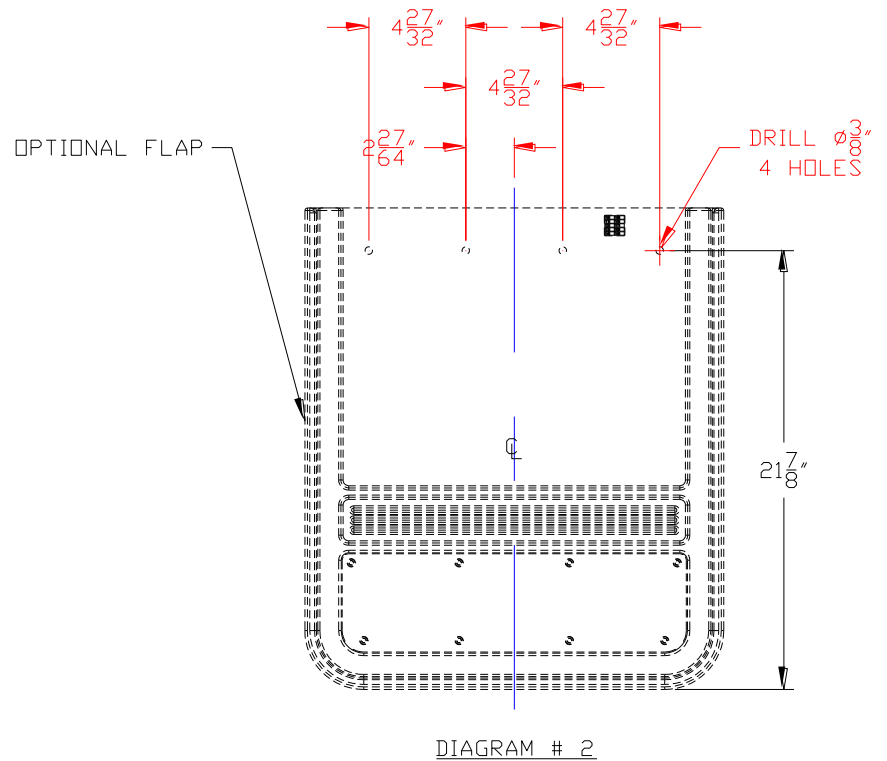
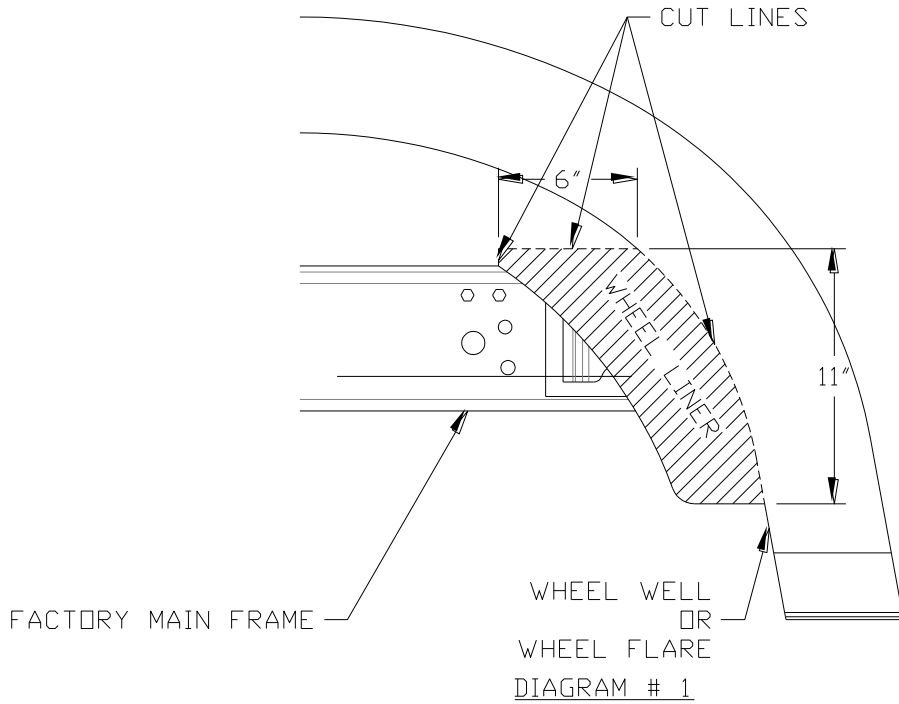

4. Assemble optional mud flap, mud flap bracket, pressure plate and rear strip with four carriage bolts, four 3/8" flat washers, four 3/8" lock washers and four 3/8" hex nuts (See diagram #3).

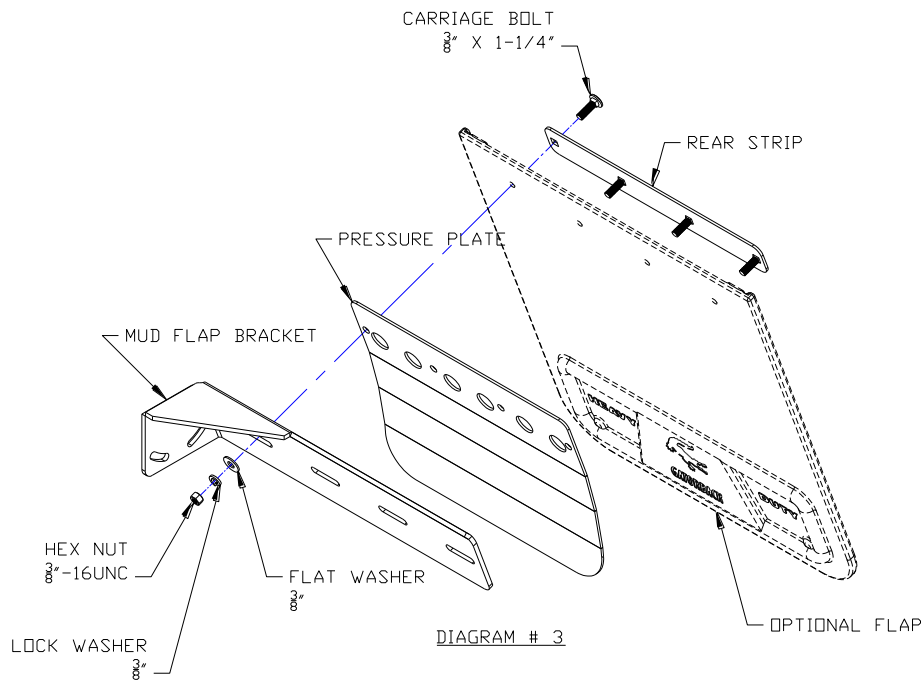

5. Install two clinch nuts to the two factory holes using the attached clinch nut placing tool instructions (See diagram #4 for location).
6. Install the offset bracket to the factory main frame then mud flap assembly bracket to the offset bracket (See diagram #4). Loosely secure at this point.
7. Adjust the mud flap assembly from diagram #4 into the right angle then tighten all three bolts from step #6.

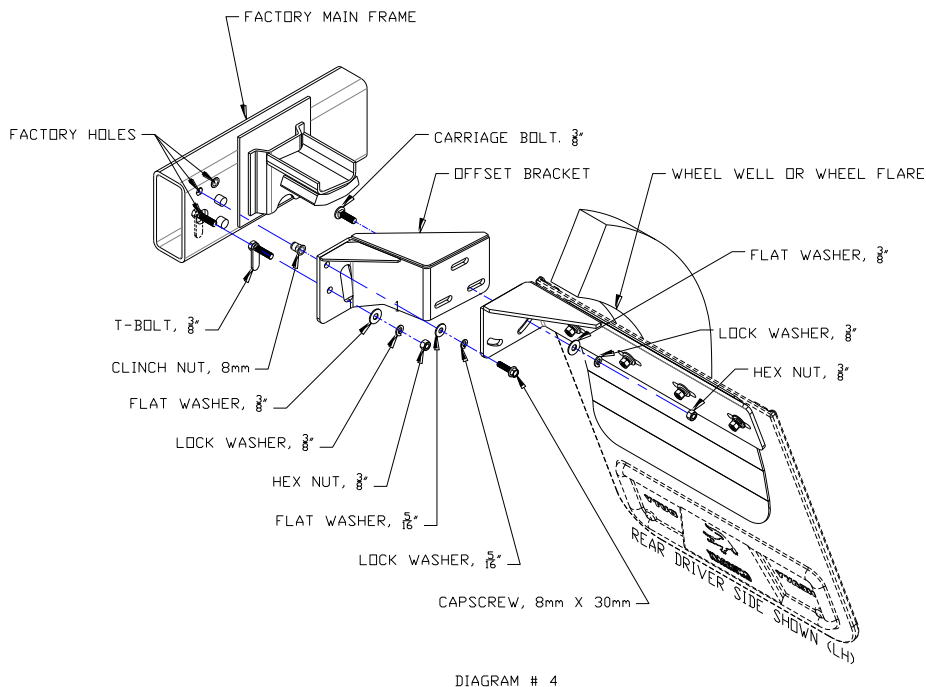

✓ Check all fasteners for tightness. Repeat procedure on the other side