

GATORBACK

No-Drill System

No drilling into your vehicle fender required!

**2014, GMC, 12"
Mud Flap Set, 5/8" Offset, Rear
Mounting Diagram & Instructions
Part #756801**

IMPORTANT:

Manufacturer is not responsible for negligent use of vehicle with mud flaps installed, including over-tightening of screws and bolts causing damage to vehicle or mud flaps.

TOOLS REQUIRED-

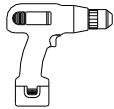

Electric or Chargeable
1/2" or 3/8" Drill



3/8" Socket Driver

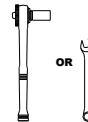

7/16" Open Wrench
or Socket Wrench



#15 Torque
Screwdriver

SCREWS / FASTENERS / WASHERS / FLAPS - PARTS BAG # 750580

a) (1) Flap Assembly,
Rear, DS



b) (1) Flap Assembly
Rear, PS



c) (2) Screw, TEK
1/4" x 1.25"
Part #010011



d) (6) Capscrew, SS
1/4" x 1"
Part #014007

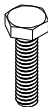

e) (8) Washer, SS
0.281 x 1"
Part #018028



f) (3) Mount Clip, DS
w/ Clinch Nut
Part #750582

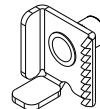

g) (3) Mount Clip, PS
w/ Clinch Nut
Part #750584

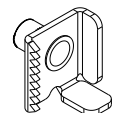

INSTALLATION (For ease of installation it is suggested that the wheel be removed)

1. Before you install your Precision Mud Flap, see the diagram and parts list for all necessary parts. Cut the protective plastic and peel away from the stainless steel. Start on the driver's side.
2. Install each mud flap clip to the holes #1 to #3 with a capscrew and a flat washer then tighten screws until the bottom tab of the mud flap clip just passed through the bottom of the slotted hole of holes #1 to #3.
3. Remove the factory screw on the wheel tub as shown on the diagram and reinstall the factory screw on hole #5 through the factory hole #6, loosely secure at this point. Ensure the three installed mud flap clips are behind the factory wheel well.
4. Square the flap with the tire while putting pressure against the wheel well and tighten the factory screw on hole #5.

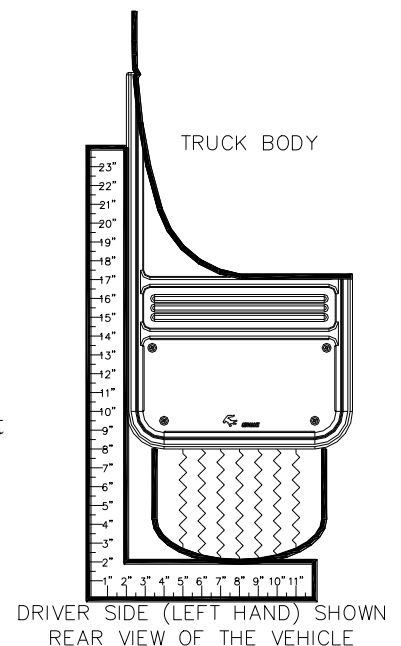

5. Now secure the flap with a flat washer and a tek screw on hole #4 through the wheel tub.
6. Secure the flap to the wheel by sliding each installed mud flap clips on hole #1 to #3 to the wheel well until mud flap clip's teeth are gripped behind the wheel well then tighten the screws.
7. Repeat procedure for the passenger side.

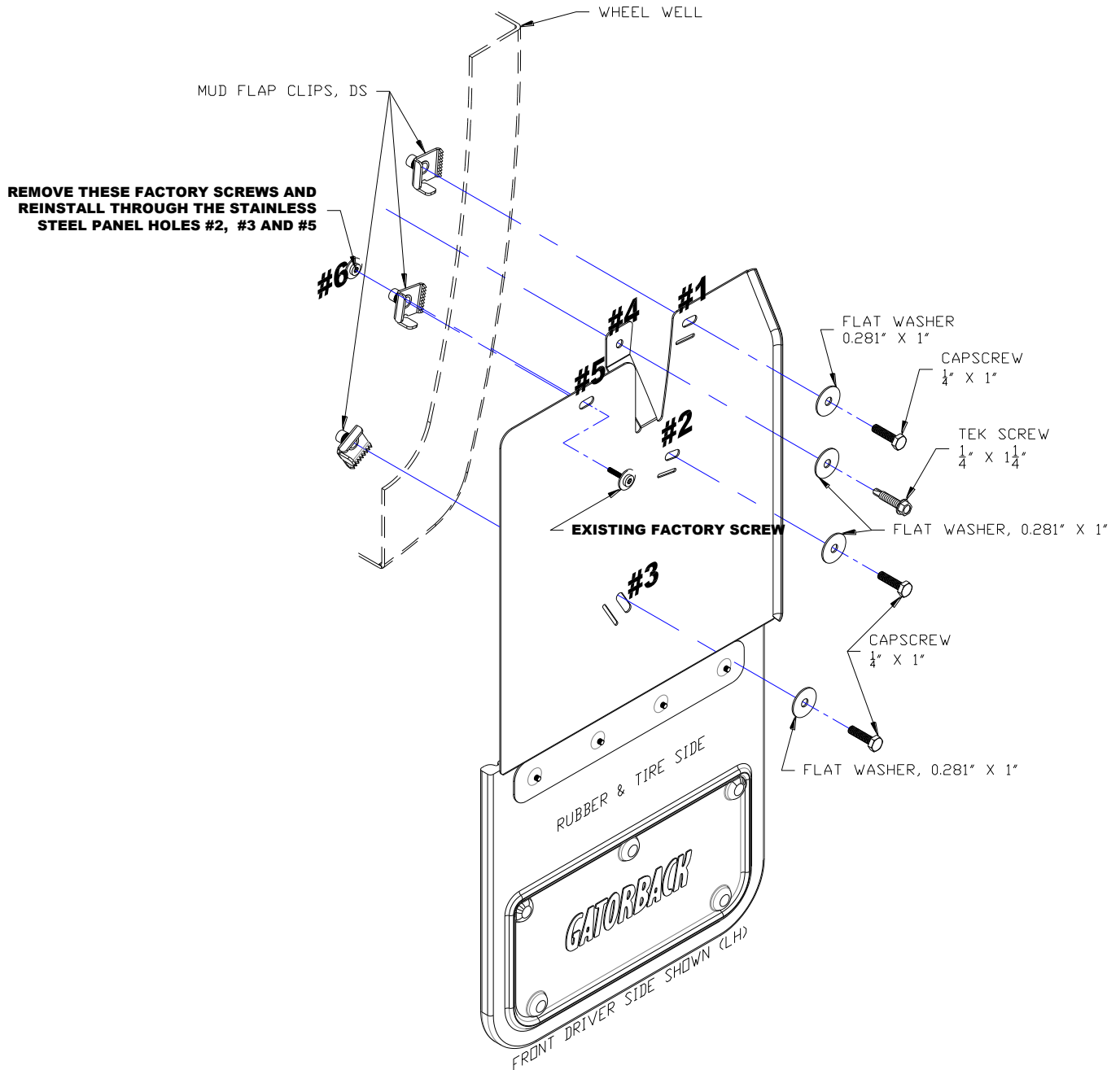

IMPORTANT:

Manufacturer is not responsible for negligent use of vehicle with Mud Flaps installed, or over tightening of screws and bolts causing damage to vehicle or mud flaps.