



GATORBACK MUDFLAPS

GCR42R 2017 F150 Raptor Rear Gatorback CR Mudflap Kit Installation Instructions GCR42R

766302/766308

IMPORTANT

The manufacturer is not responsible for negligent use of vehicle with mudflaps installed, including over-tightening of screws and bolts causing damage to vehicle or mudflaps.

TOOLS REQUIRED:

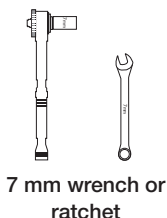

7 mm wrench or ratchet

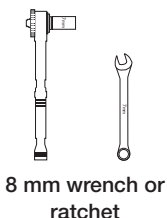

8 mm wrench or ratchet

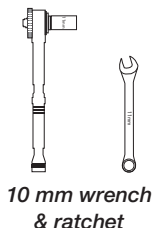

10 mm wrench & ratchet

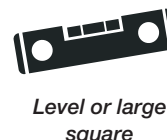

Level or large square

PARTS:

1. (2) Gatorback CR Mud Flap (DS & PS)

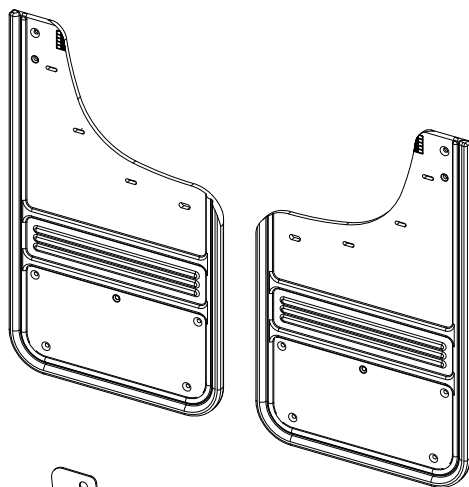

2. (2) Washer Plate (DS & PS)
Part# 759979

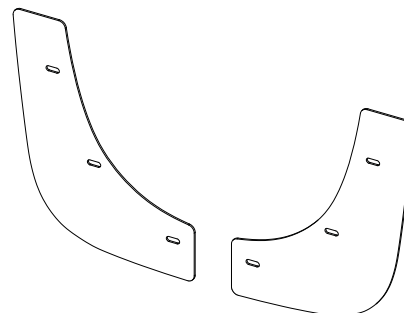

3. (2) Backing Plate (DS & PS)
Part# 759976

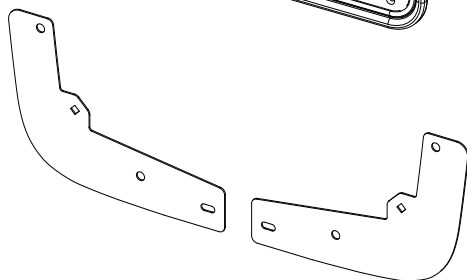

4. (2) Brace (DS & PS)
Part# 759977
759978

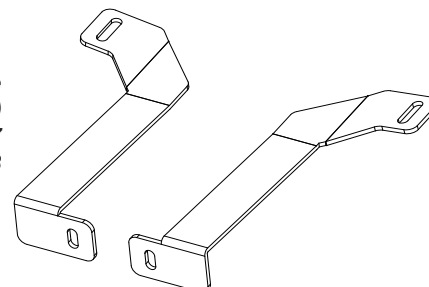

FASTENERS:

5. (2) Nylon Snap-In Nuts for #8 screw size
Part# 054044



6. (6) Flanged Hex Head Screw
M4.2-1.41 x 25mm
Part# 016041



7. (6) Black Nylon Washer
0.265" ID 0.625" OD
Part# 054071



8. (4) Hex Head Cap Screw
M6 x 35mm
Part# 012028



9. (8) Oversize Washer
0.281" ID 1" OD
Part# 018052



10. (4) Lock Washer
M6
Part# 024000

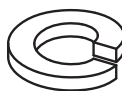

11. (4) Hex Nut
M6
Part# 025022

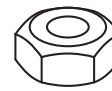

INSTALLATION:  Installation video available on our YouTube channel: youtube.com/c/TruckHardwareLtd

Note: Please refer to diagram during installation. Power tools not recommended.

1. START ON DRIVER SIDE (DS) REAR

2. INSTALL BACKING PLATE

- a. Remove 2x factory fender flare screws on inner fender.
- b. Insert Nylon Snap-In Nut #5 into square hole on Backing Plate (#3).
- c. Install Backing Plate (#3) between fender flare and body (pull fender flare away slightly from fender to insert).
- d. Line up two round holes in Backing Plate #3 with two round holes in fender flare.

3. INSTALL GATORBACK CR MUD FLAP (DS) AND WASHER PLATE

- a. Loosely install Mudflap (#1) with Washer Plate (#2) using 3x #8 Flanged Hex Head Screws (#6), and 3x Nylon Washers (#7).

4. INSTALL BRACE (DS)

- a. Remove plastic push pin behind fender opening.
- b. Loosely attach Brace #4 to fender (see previous step) using 1x M6 Hex Head Cap Screw (#8), 2x Oversized Washer (#9), 1x Lock Washer (#10), and 1x M6 Hex Nut (#11).
- c. Loosely attach Brace to Gatorback Mud Flap using 1x M6 Hex Head Cap Screw (#8), 2x Oversize Washer (#9), 1x Lock Washer (#10), and 1x M6 Hex Nut (#11).

5. ADJUST MUD FLAP POSITION AND ALIGNMENT

- a. Adjust horizontal position of mud flap.
- b. With a level (bubble/digital) on the bottom edge of the mud flap, adjust until level.
- c. Carefully tighten all screws and double check that mudflap is still level.
- d. Adjust forward-back position of Brace so that mud flap is approximately parallel to tire tread.

5. TIGHTEN ALL FASTENERS

6. REPEAT PROCEDURE ON PASSENGER SIDE (PS)

DIAGRAM (DRIVER SIDE)

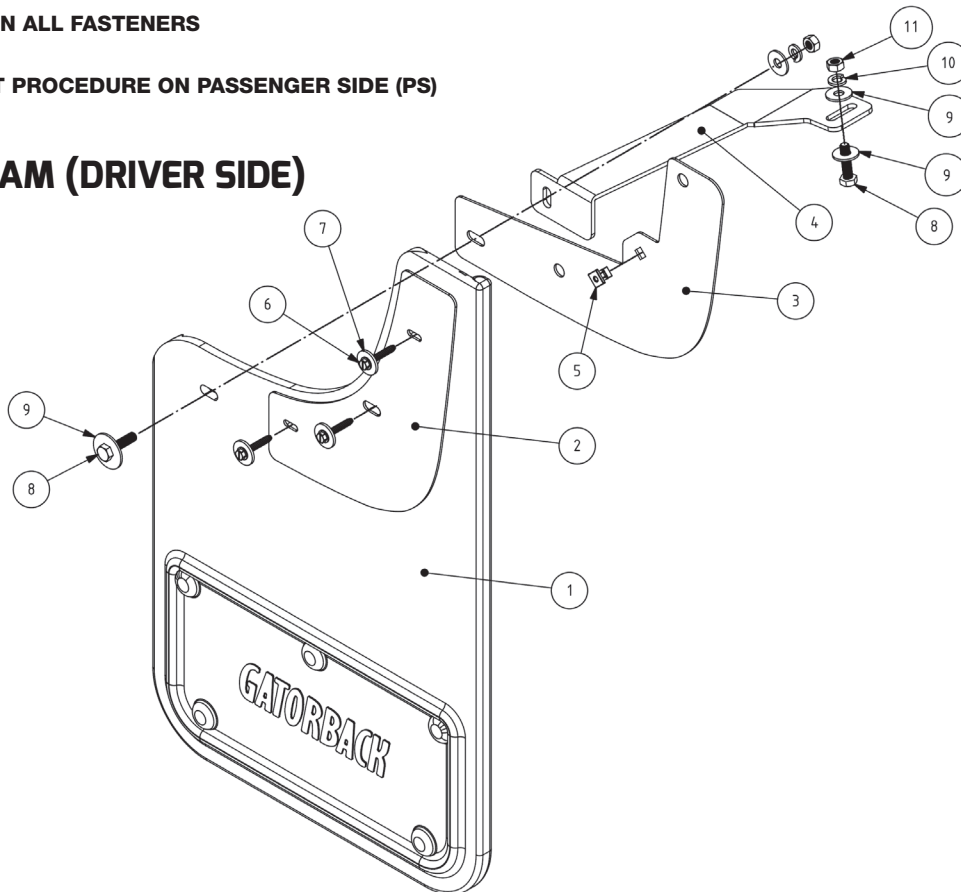

***** NOTICE *****

These instructions and enclosed parts have been provided in response to the Ford 2015 F150 SVE Bulletin. Any deviation of the installation and/or hardware may result in premature corrosion. The Manufacturer and/or Dealer Distributor are not responsible for negligent use or installation.