

**STEP 6:
INSTALL REAR BRACE**

Locate the two 5/8" x 1" long bolts that are welded to thin straps (bolt guides), see fig 6.1. Using the straps install the bolt guides into the frame cross member just behind the axle, see fig 6.2 & 6.3. The straps on the bolt guides will keep them from turning. Install the rear brace by positioning the two large slots over the 5/8" bolts of the bolt guides, see fig 6.4. Attach the rear brace to the center section and the rear cross member with two 1/2" x 1-1/2" long bolts, lock washers and flat washers. Hand tighten only at this time. Using the 5/8" flange nuts, attach the rear brace to the frame cross member with the bolt guides. If the pickup is equipped with dual exhaust, it may be helpful to pry the exhaust downward while installing the flange nut on the driver side bolt guide, see fig 6.5.

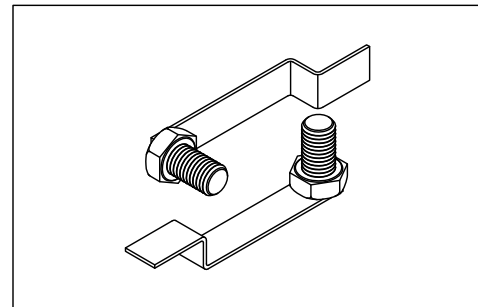

FIGURE 6.1

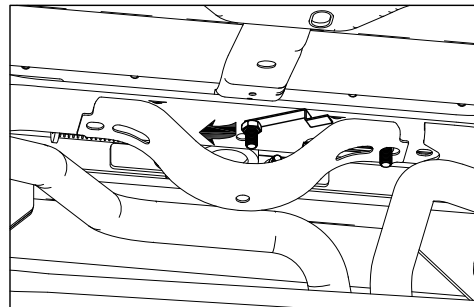

FIGURE 6.2: View under bed looking from floor to area above axle

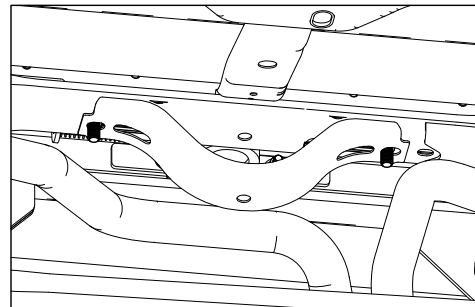

FIGURE 6.3: View under bed looking from floor to area above axle

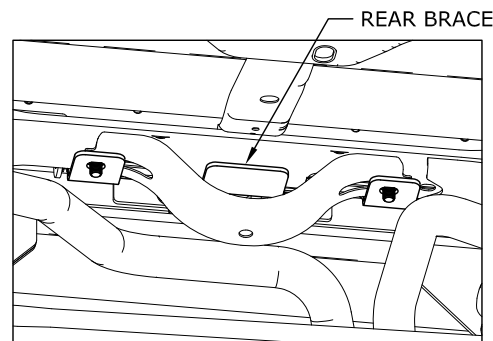

FIGURE 6.4: View under bed looking from floor to area above axle

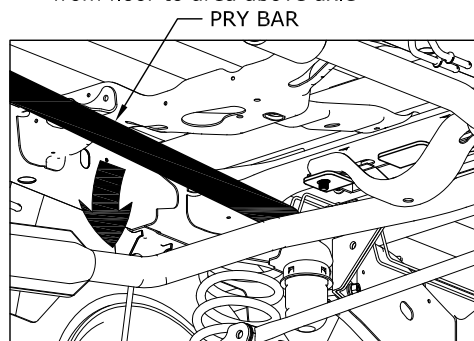

FIGURE 6.5: View under bed looking from floor to area above driver side exhaust pipe.

STEP 7: TIGHTEN HARDWARE

Before tightening the hitch hardware make sure that the center section is tight against the bottom of the truck bed, and that the hitch is centered and square in relation to the truck frame. The 3/8" square hole in the center must be close to the center of the 3/4" hole in the truck bed. Tighten the hitch hardware in the following sequence. Torque the 5/8" flange nuts to **80 ft.-lbs.** Be sure the rear cross member is centered across frame and that the wiring harness is not pinched then tighten the rear brace to the rear cross member and center. Tighten the center to the rear cross member. Be sure that the front cross member is centered and tighten the center to the cross member. Tighten both side plate U-bolts alternating between the top and bottom threads so that the U-bolt is secured evenly. Torque nuts on U-bolts to 40 ft.-lbs. Tighten the two bolts holding the two side plates together on the driver side, then tighten the side plates to the front cross member and center. Torque all 1/2" hardware to **80 ft.-lbs.** except for the U-bolts.

Locate the axle vent tube that was disconnected from the frame at the beginning of the install. Relocate the vent by clipping the end to the frame cross member as shown, see fig 7.1.

STEP 8: INSTALL SAFETY CHAINS

To install the safety chain brackets it is necessary to drill four 1/2" holes through the truck bed floor. Drill the holes so that they match up with the two sets of holes on each side of the center, see fig 8.1. This may be done by drilling the 1/2" holes from the bottom using the center as a guide, or by drilling a smaller pilot hole from the bottom and drilling the 1/2" holes from the top side of the bed. Drop a U-bolt through each pair of holes from the top side of the truck bed floor. Place a spring and lock nut on each of the four legs, see fig 8.2. Tighten the lock nuts until they are flush with the bottom of the U-bolts.

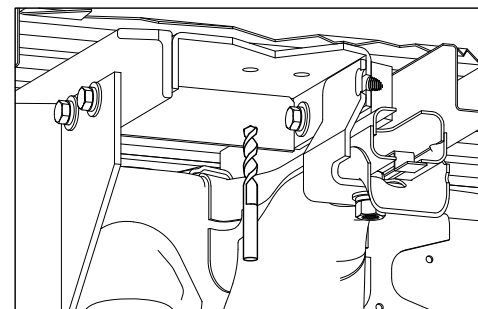

FIGURE 8.1: Cutaway view from under the bed

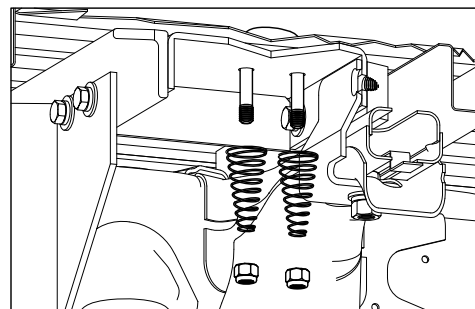

FIGURE 8.2: Cutaway view from under the bed

STEP 9: LATCH PIN OPERATION

To operate the latch pin of the hitch, use the L-shaped handle provided. Insert the square end of the handle into the 3/8" square hole in the center from the top side of the truck bed. To retract the latch pin, rotate the handle counter clockwise. Place the 2-5/16" ball into the hitch receiver. Engage the latch pin by rotating the handle clockwise. Be certain the latch pin passes through the holes in the 2-5/16" ball and fully engages through the hitch receiver. This can be determined by whether or not the handle returns to its original location. Grease the square base of the 2-5/16" Ball.

Copyright 2011
B&W Custom Truck Beds, Inc.
ALL RIGHTS RESERVED



B&W Trailer Hitches
1216 HWY 224 / PO Box 186
Humboldt, KS 66748
P:620.473.3664
F:620.473.3766

NOTE: *We recommend reading instructions before beginning the installation.*

WARNING: *The tow vehicle's towing capacities should Under NO Circumstances be exceeded.*

Turnoverball™ Gooseneck Hitch Installation Instructions

Model 1309R

Dodge 2009 - 2012

1/2 Ton, Long & Short Bed
Two and Four-Wheel Drive

Call or Email us for Instalation Support
hitches@turnoverball.com www.turnoverball.com

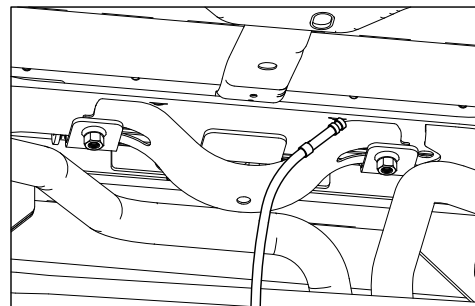
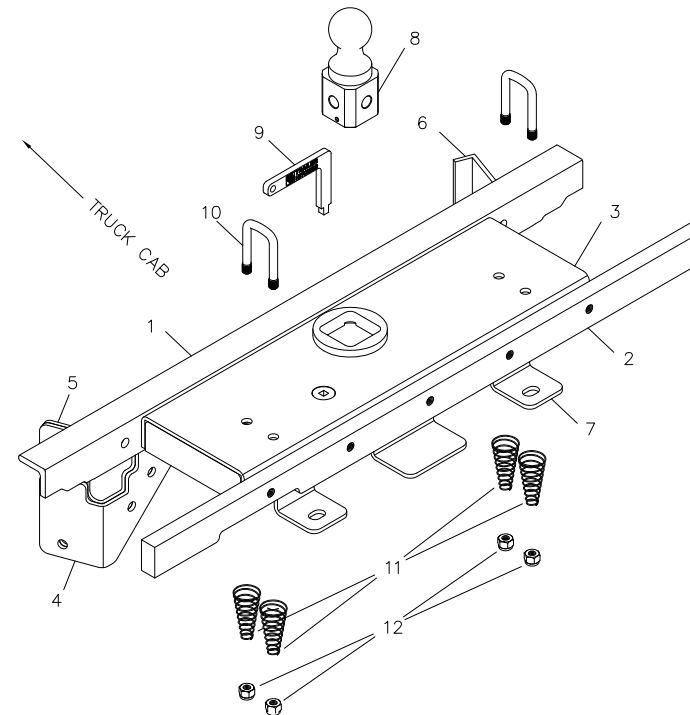

FIGURE 7.1: View under bed looking from floor to area above axle

BEFORE INSTALLING

OVERHEAD LIFTING DEVICE

An overhead lifting device such as chain falls, engine hoist, or cable come-a-long, can be used to lift the center section of the hitch in place. If these are not available, a portable, mechanical lifting device can be purchased through B&W. Lower a loop of chain or rope through the 4" hole in the truck bed floor and attach it to the latch pin in the round hitch receiver tube in the center section. See step 9 for instructions on latch pin operation. Use the lifting device to raise the center section until the round hitch receiver tube that protrudes from the center section fits into the 4" hole in the truck bed floor. Maintaining upward pressure may facilitate fastening the cross members to the center section, especially if the truck bed floor has been distorted downward from heavy use.

WARNING

Most trucks have FUEL LINES and/or BRAKE LINES and/or ELECTRICAL WIRES located along the frame rails where B&W Turnoverball™ hitches install. Carefully examine the location of fuel lines, brake lines and electrical wires BEFORE INSTALLATION. Be certain you will not damage fuel lines, brake lines or electrical wires when positioning hitch components, drilling holes, tightening fasteners. The fuel tank vent, located on top of the gas tank, can be easily damaged during the installation of the hitch components. Care must be taken when positioning the front cross member and center section components.

CLEARANCE WARNING

On short bed trucks, **BEFORE INSTALLING THIS HITCH**, check for adequate turning clearance between the front of all of your trailers and the truck cab.

WARNING

DO NOT INVERT the ball in the socket when carrying heavy loads. The ball may hit the top of the differential. Remove the ball from the socket before loading. A plug for the socket is available from B&W.

WARNING

The tow vehicle manufacturers recommended towing capacities should under NO circumstances be exceeded.

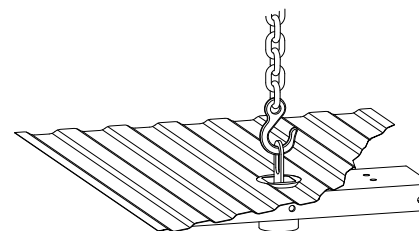

HARDWARE KIT

- 5 - 1/2-13 X 2-1/4" HEX HEAD CAP SCREW
- 8 - 1/2-13 X 1-1/2" HEX HEAD CAP SCREW
- 12 - 1/2-13 HEX FINISH NUT
- 17 - 1/2" SPLIT LOCK WASHER
- 13 - 1/2" FLAT WASHER
- 2 - 1/2-13 X 5.5 X 4.25 U-BOLT
- 2 - 5/8-11 FLANGE NUT
- 2 - BOLT GUIDE

SAFETY CHAIN KIT

- 1 - L-SHAPED LATCH PIN HANDLE
- 2 - 1/2" U-BOLT
- 4 - 1/2" CENTER LOCK NUT
- 4 - CONICAL SPRING

PARTS LIST

- 1 - FRONT CROSS MEMBER
- 2 - REAR CROSS MEMBER
- 3 - CENTER SECTION
- 4 - OUTSIDE DRIVER SIDE PLATE
- 5 - INSIDE DRIVER SIDE PLATE
- 6 - PASSENGER SIDE PLATE
- 7 - REAR BRACE
- 8 - 2-5/16" BALL
- 9 - L-SHAPED LATCH PIN HANDLE
- 10 - SAFETY CHAIN U-BOLTS
- 11 - CONICAL SPRINGS
- 12 - 1/2" CENTER LOCK NUTS

**STEP 1A:
MARKING HOLE LOCATIONS IN 5'7" AND 6'4" BEDS**

Begin by marking the locations for the 4" diameter and 3/4" diameter holes in the truck bed floor. To mark the location of the 4" hole, measure from the back of the truck bed floor by hooking a tape measure over the back of the sheet metal and mark the floor at 40-1/8" and centered between the wheel wells. This location should be in the center of a low rib in the bed floor. The 3/4" hole will be in the middle of next low rib toward the driver side. Locate the mark for the 3/4" hole 37-3/8" from the back of the truck bed floor, measuring as before, in the middle of the low rib which must be 4-3/4" from the center of the 4" hole, see fig 1.1. The locations of these holes are critical to the installation of the hitch, so measure, mark, and saw carefully.

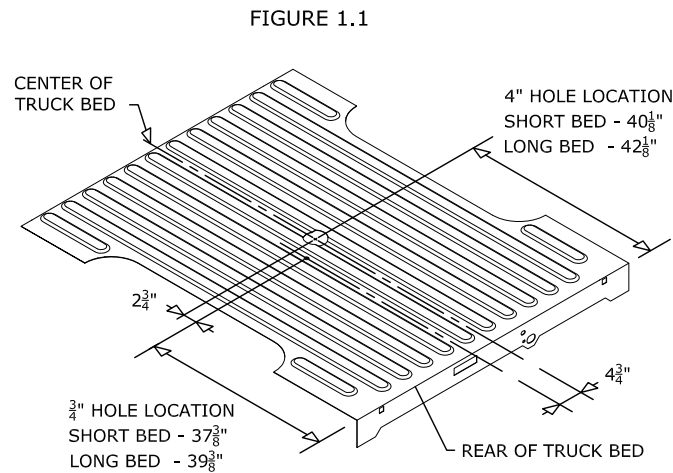

**STEP 1A:
MARKING HOLE LOCATIONS IN 8' BEDS**

Begin by marking the locations for the 4" diameter and 3/4" diameter holes in the truck bed floor. To mark the location of the 4" hole, measure from the back of the truck bed floor by hooking a tape measure over the back of the sheet metal and mark the floor at 42-1/8" and centered between the wheel wells. This location should be in the center of a low rib in the bed floor. The 3/4" hole will be in the middle of next low rib toward the driver side. Locate the mark for the 3/4" hole 39-3/8" from the back of the truck bed floor, measuring as before, in the middle of the low rib which must be 4-3/4" from the center of the 4" hole, see fig 1.1. The locations of these holes are critical to the installation of the hitch, so measure, mark, and saw carefully.

**STEP 1B:
CUTTING HOLES**

After marking the hole locations cut the 3/4" and 4" holes with hole saws or with a saber saw equipped with a metal cutting blade. If the truck has a plastic bed liner, you may drill through both, but it is more difficult to accurately locate the midpoint between the wheel wells, and the location of the 3/4" hole. You must also make sure that the liner does not move while sawing the holes.

**STEP 2:
INSTALL REAR CROSS MEMBER**

Before the hitch can be installed, a wiring harness and vent tube must be relocated. The wiring harness that must be relocated runs along the top of the frame cross member that is just behind the axle. The harness is secured to the top of the cross member by four plug fasteners. Pull each of the fasteners. Push the wiring harness toward the rear of the truck to make room for the rear cross member. The vent tube coming out of the rear axle is clipped onto the same frame cross member. Remove the vent tube, clip and all. Allow this to hang during installation. It will be relocated after the hitch is installed.

The rear cross member is the 2 x 1 bar with the threaded holes. The cross member will be installed from the passenger side, just in front of the rear tire. Insert the cross member between the frame and the top suspension control arm with the notch machined into the cross member going first and facing the rear. Slide the leading end of the cross member above the exhaust and over the frame of the truck on the driver side while moving that end toward the rear, see fig 2.1. As the leading end gets to the driver side, raise the opposite end of the cross member up until both ends of the cross member can be positioned over the top of the frame with the cross member laying flat and the notch still facing the rear, see fig 2.2 Adjust the cross member so that it is parallel to the axle and slide it toward the rear of the truck until it is over the frame cross member where the wiring harness was attached. Rotate the cross member from flat to vertical so that the notch on the driver side of the cross member is down, see fig 2.3. This notch provides clearance for the wiring harness and an exhaust bracket that is present on models that have dual exhaust. Slide the cross member rearward as far as possible while making sure that the wiring harness does not get pinched or smashed. The cross member will rest on the frame and should be suspended just above the frame cross member.

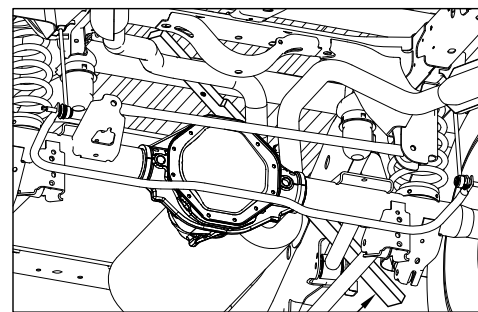

FIGURE 2.1: View under bed looking from rear towards the axle

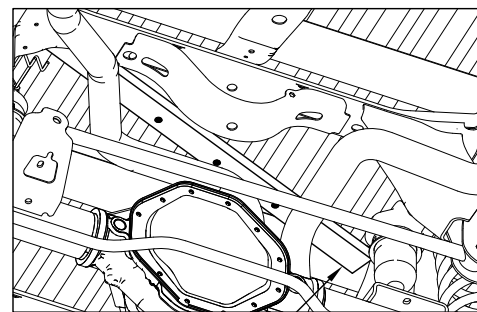

FIGURE 2.2: View under bed looking at area above axle

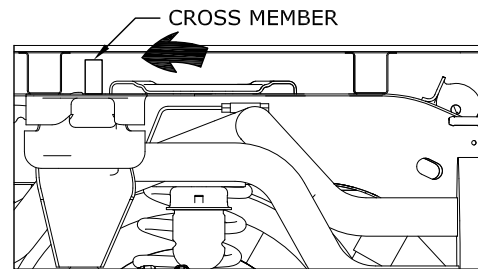

FIGURE 2.3: Cut-away view of under bed area looking from passenger side of truck

**STEP 3:
INSTALL CENTER SECTION**

Position the center section so that the 4" diameter raised area of the center fits into the 4" diameter hole in the truck bed while the 3/8" square hole is centered under the 3/4" diameter hole in the truck bed. When installed the round receiver will be almost directly above the axle of the pickup. If the pickup is equipped with dual exhaust the installation is more difficult. From behind the rear axle and with the bottom side of the center facing the passenger side of the truck, send the end of the center without the spring over the axle first, see fig. 3.1. Send the lead end of the center toward the front of the truck and to the passenger side far enough so the end of the center toward the rear of the truck will clear the exhaust, see fig 3.2. Once the hitch is clear of exhaust, rotate, and lift it so that the 4" raised area is toward the bottom of the truck bed. Slide the center rearward over the exhaust until the 4" diameter raised portion is in the 4" diameter hole in the truck bed while the 3/8" square hole is centered under the 3/4" diameter hole in the truck bed, see fig 3.3.

If available, an overhead lifting device can be attached to the latch pin of the center section at this time to apply upward pressure on the center, holding it in place.

Slide the rear cross member forward until it makes contact with the center section. Line the holes in the rear cross member up with the slots in the center. Attach the center to the rear cross member using the two outside slots and middle slot in the center. Thread a 1/2" x 1-1/2" long bolt into each threaded hole in the rear cross member adding a lock washer, and flat washer to each connection. Hand tighten hardware at this time. Do not fully tighten.

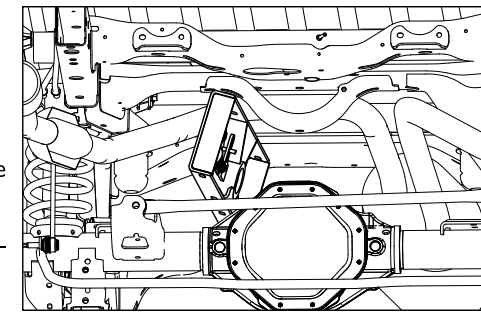

FIGURE 3.1: View under bed looking from rear towards the axle

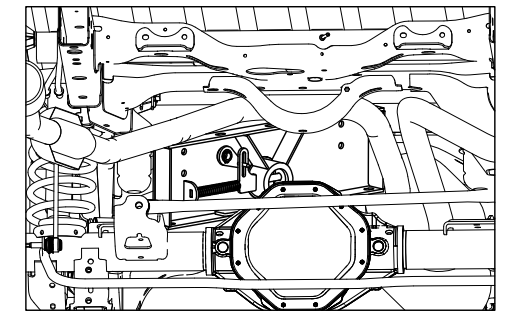

FIGURE 3.2: View under bed looking from rear towards the axle

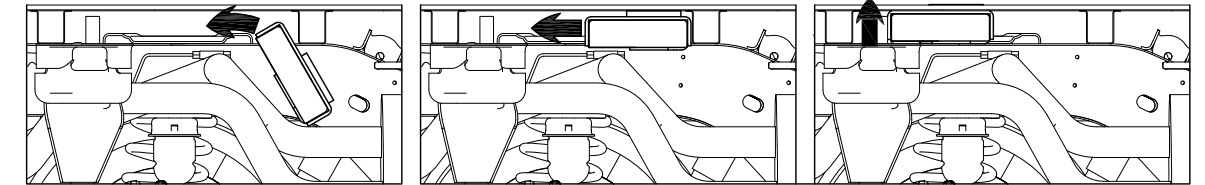

FIGURE 3.3: Cut-away view of under bed area looking from passenger side of truck

**STEP 4:
INSTALL FRONT CROSS MEMBER**

The front cross member is the 2 x 2-1/2 angle. Install the cross member from the passenger side in front of the rear tire, see fig 4.1. Position the cross member so that it spans the frame and sits in an upside down "V" position with the holes toward the rear of the truck. Slide the cross member rearward to the center section. Center the cross member in the truck so that the holes in the cross member will line up with the slots in the center. Using an adjustable wrench or other means, stand the cross member up so that leg of the angle with the holes is vertical. Slide the cross member back against the center, see fig 4.2. Attach the center and the cross member with two 1/2" x 2-1/4" long bolts in the two center holes only. The bolt heads must be toward the rear of the truck. Add a flat washer, lock washer, and finish nut to both bolts and hand tighten. Do not fully tighten at this point.

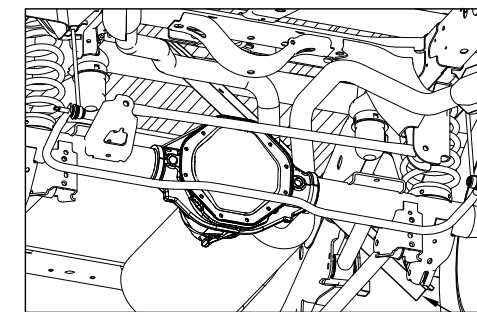

FIGURE 4.1: View under bed looking at area above axle

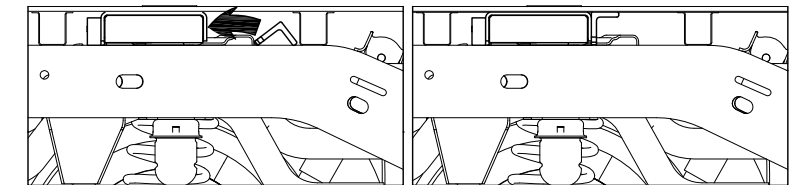

FIGURE 4.2: Cut-away view of under bed area looking from passenger side of truck

**STEP 5:
INSTALL SIDE PLATES**

Place one U-bolt in front of each coil spring around the pickup frame as shown in fig 5.1. To ease installation of the side plates, start with the U-bolts pulled back from the frame so that the ends of U-bolts are flush with the wall of the tubular frame, see fig 5.2.

Position the side plate with 2 bends so that the two round holes match up to the U-bolt on the passenger side and push the U-bolt into the holes, see fig 5.3. Secure the side plate and U-bolt with lock washers and nuts. Attach this side plate to the front cross member and center using a 2-1/4" long bolt through the center, cross member and side plate along with a lock washer, two flat washers, and a finish nut. Finish attaching the side plate by placing another 1/2" x 1-1/2" long bolt through the cross member and the side plate adding a flat washer, lock washer, and finish nut. Hand tighten these connections.

The two side plates that are left will be combined to secure the hitch to the frame on the driver side. Using the slot provided, maneuver the first side plate around the brake lines and line the holes up with the

U-bolt, see fig 5.4. Insert the U-bolt into the holes on the side plate just enough to hold the side plate in place. Position the second side plate over the first as shown, see fig 5.5. Insert the U-bolt into the holes of the second side plate. Secure the side plates and U-bolt with lock washers and nuts. Fasten the two side plates together as shown using 1/2 x 1-1/2" long bolts, lock washers and finish nuts, see fig 5.6. Attach these side plates to the front cross member and center using a 2-1/4" long bolt through the center, cross member and side plate along with a lock washer, two flat washers, and a finish nut. Finish attaching the side plates by placing a 1/2" x 2-1/4" long bolt through the cross member and the side plates adding a flat washer, lock washer, and finish nut. Hand tighten these connections.

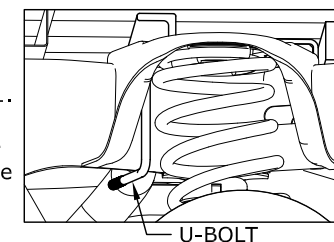

FIGURE 5.1: View of driver side suspension spring (Tire and wheel well shroud not shown)

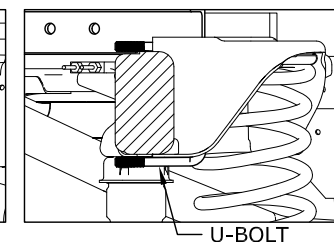
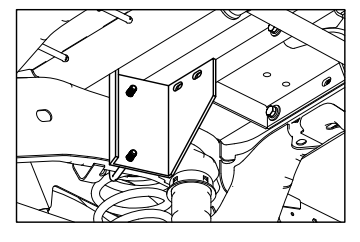

FIGURE 5.2: View of driver side suspension spring area looking towards the rear of the truck (frame is shown cutaway)



Note: Figure 5.3: View of passenger side plate looking from floor up at the passenger side frame (fuel tank is not shown)

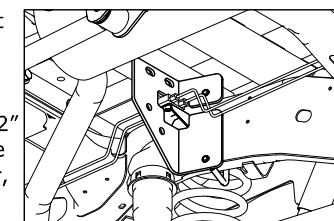

Figure 5.4: View of driver side plate looking from floor up at the driver side frame (fuel tank is not shown)

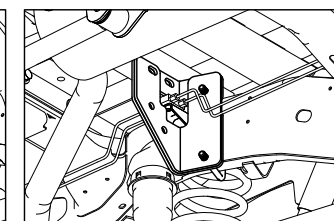

Figure 5.5: View of driver side plate looking from floor up at the driver side frame (fuel tank is not shown)

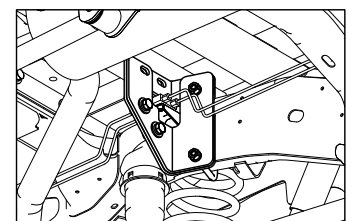

Figure 5.6: View of driver side plate looking from floor up at the driver side frame (fuel tank is not shown)