

<THESE INSTRUCTIONS MUST BE GIVEN TO THE END USER>



B&W Trailer Hitches

1216 HWY 224 / PO Box 186
Humboldt, KS 66748
P: 620.473.3664
F: 620.473.3766

Call or Email us for
Installation Support
hitches@turnoverball.com
www.turnoverball.com

Turnoverball™ Gooseneck Hitch Installation Instructions

MODEL 1384

2014 RAM 2500 3/4 Ton Long & Short bed Trucks.

PARTS LIST		
ITEM	DESCRIPTION	QTY
1	Center Section	1
2	Safety Chain Bracket	1
3	Threaded Block	2
4	Latch Pin Handle	1
5	Plastic Spacer Block	1
6	1/2" x 1-1/2" x 3-1/8" U-Bolt	2
7	2-5/16" Ball	1
8	Conical Spring	4
9	1/2" Center Lock Nut	4
10	Hole Template	1

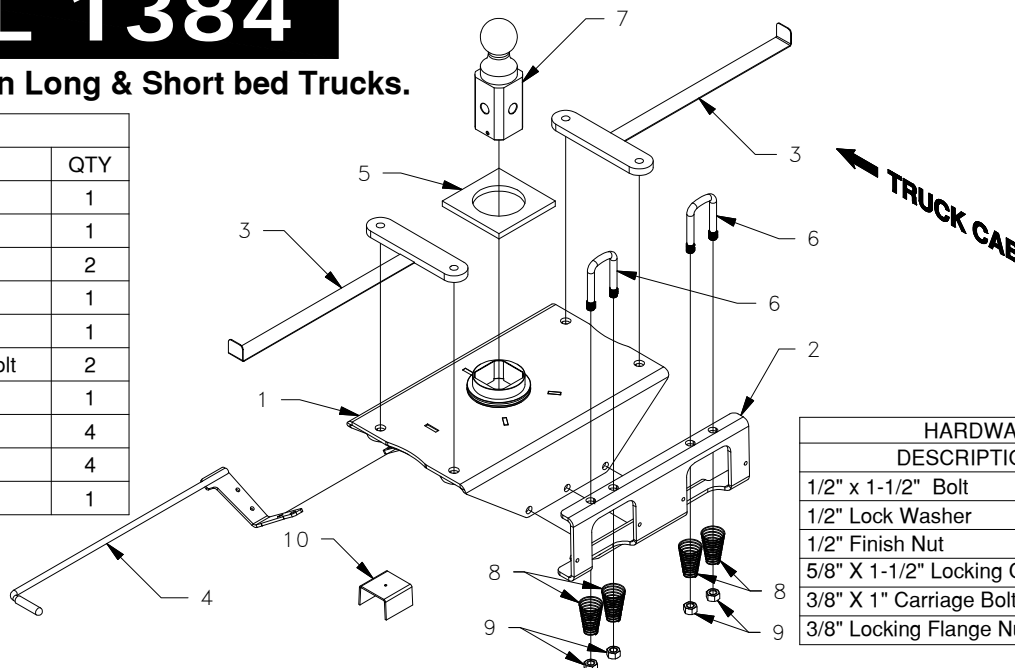

HARDWARE KIT	
DESCRIPTION	QTY
1/2" x 1-1/2" Bolt	3
1/2" Lock Washer	3
1/2" Finish Nut	3
5/8" X 1-1/2" Locking Cap Screw	4
3/8" X 1" Carriage Bolt	2
3/8" Locking Flange Nut	2

ATTENTION:

If you intend to use an 18K Companion 5th Wheel RV Hitch model 3000 in a **2014 or newer RAM** truck, please call us at 800-248-6564 for a kit that fills voids in the truck bed rib pattern. Using the model 3000 Companion on a **2014 or newer RAM** without the supplemental kit could result in damage. RV Models 3400 and 3500 do not need a supplemental kit.

WARNING

Failure to comply with the safety information in these instructions could result in serious injury or death.

- ⚠ Read all installation and operating instructions along with all labels before using this product.
- ⚠ Without proper knowledge, towing can be a dangerous activity. Understand all the risks involved with towing before proceeding. For information on towing safety, see "**The Trailer Handbook: A guide to Understanding Trailer and Towing Safety**" from the National Association of Trailer Manufacturers, www.NATM.com.
- ⚠ The Turnoverball hitch comes equipped with a 2-5/16" ball. Trailers towed with the ball provided must have a 2-5/16" coupler. Towing with a larger coupler could cause loss of attachment between the trailer and the tow vehicle.
- ⚠ Do not modify this product in any manner. Doing so could alter its integrity and lead to a loss of attachment between the trailer and the tow vehicle.
- ⚠ Do not exceed tow or tongue rating of coupler, tow or tongue rating of hitch, or tow or weight ratings of truck or trailer. See vehicle and trailer manufacturer information for ratings. Exceeding these ratings may cause damage to towing components or loss of attachment between the trailer and truck.
- ⚠ Adding components such as a Turnoverball hitch to the chassis of any vehicle can be hazardous. There is potential for unexpected combustion of fuel, electric shock, burns, shifting or falling of unstable vehicle, damage to vehicle, injury from tool usage and many other hazards. This installation must be completed by someone who is aware of the hazards involved. This person must be knowledgeable of proper safety procedures for a vehicle modification of this nature, and for usage of the equipment required to perform the installation.

PREPARING TO INSTALL

NOTICE: In some instances, the ball should **NOT** be turned over and stowed in the socket. Doing so could cause damage to the truck's suspension. If the truck's suspension has a stabilizer between the top of the differential housing and the frame as shown in figure A1, the stowed ball could hit the member, damaging the truck's suspension.

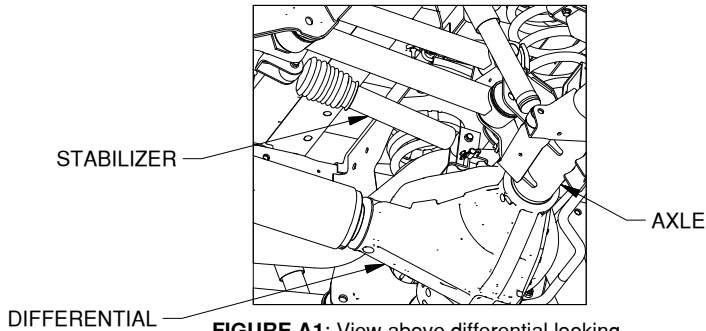

FIGURE A1: View above differential looking from in front of the driver side rear tire.

NOTE: Remove all parts from the packaging and familiarize yourself with all the parts and tools required. Use the parts list on the front page to verify that all parts and hardware are present.

TOOLS REQUIRED

- Impact wrench or ratchet with 10mm, 9/16", 3/4" & 15/16" sockets.
- Marking tool (pencil or permanent marker)
- 3-1/2" hole saw
- Drill with 9/16" & 1/4" bits
- Ear protection
- Lifting device
- Tape measure
- Pry Bar
- Flashlight
- Eye protection
- Torque wrench
- Center punch
- Soap and water

1. **Determine cab clearance:** Under the truck bed, measure from the rear most edge of the C-channel frame crossmember (over the axle) to the end of the bed, see figure A2, Length A. Next, inside the bed, measure the length of the bed from the rear edge to the front, see figure A2, Length B. Subtract the crossmember measurement (length A) from the bed measurement (Length B). Then subtract an additional 8-1/4" inches. This will give you the amount of clearance you have between the 2-5/16" ball location and the cab. Measure the distance from the center of the trailer's coupler to the farthest forward corner point of the trailer. Compare this distance to the measurement from the center of the ball to the cab. These measurements will allow you to see how much clearance you will have between the cab and the trailer while towing and turning, see figure A3

⚠ Cab clearance on short bed trucks is very limited when towing certain trailers. Failure to insure that there will be adequate clearance, may result in significant property damage, or serious injury.

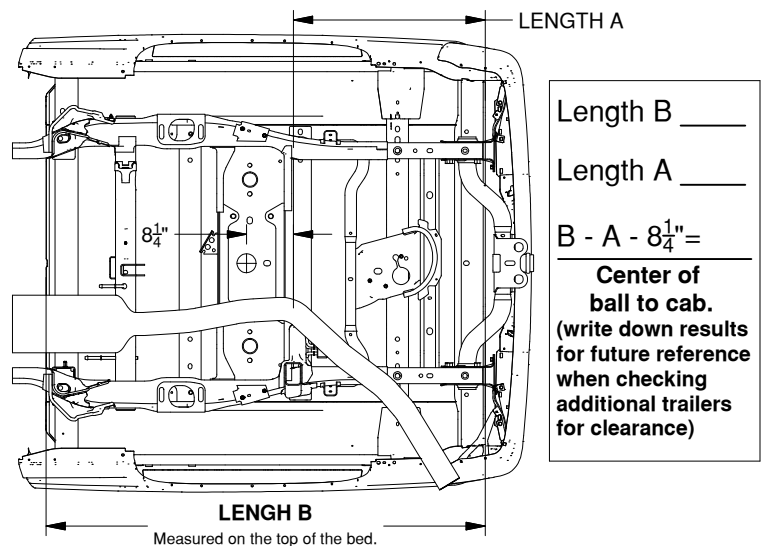

FIGURE A2: View of bottom of truck.

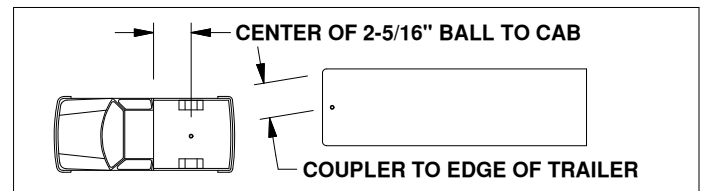

Figure A3: Truck and trailer diagram

2. **Remove the spare tire (optional).** Following the vehicle manufacturer's instructions, remove the spare tire. This will provide easier access to the area where the hitch will be installed.
3. **Remove the heatshield (optional):** Remove the bolts connecting the heatshield to the frame and set the heatshield aside for later installation.
4. **Position the vehicle.** Installation of the hitch requires the installer to be under the truck bed in the area of the rear axle. Lifting the vehicle makes this area more accessible to the installer, and improves the installation process.

⚠ WARNING: Lift vehicle using only equipment designed for lifting and positioning vehicles for service. Failure to do so may result in property damage, serious injury, or death.

5. **Prepare a lifting device (optional).** The purpose of the device is to safely hold the hitch in position during part of the installation. See figure A4 for an example. A simple mechanical lifting device is available for purchase from B&W.

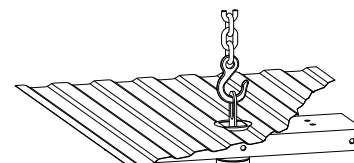

Figure A4

6. **Remove or modify fender liners as needed.**

Some vehicles are equipped with various designs of plastic liners inside the rear wheel wells. If the liner in the driver side wheel well prevents access to the opening between the bed and the frame, just over the axle, it may need to be removed or cut to install the handle.

7. **Disconnect the exhaust hanger: (optional, see secure hitch section step 3)** Locate the exhaust hanger in the rear passenger portion of the truck, see figure A5. Disconnect the exhaust from the hanger to provide improved mounting access to the center section. It is recommended that a pry bar be used to aid in disconnecting the exhaust hanger, as shown in figure A5.

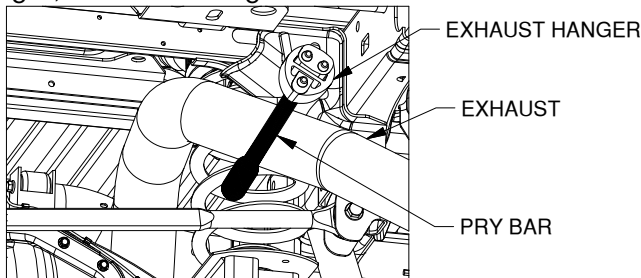

FIGURE A5: looking under truck bed towards cab.

8. **Mark the location of the 3-1/2" hole.** Insert the hole template into the center hole of the frame cross member as shown in figure A6. Push the template upward until it is flush against the bottom of the bed floor. Make a mark on the truck bed floor through the hole in the hole template using a pencil, marker, or other tool. Once the center point is marked, remove the template. Use a center punch to place an indentation in the truck bed at the center of the mark. Using a drill and a 1/4" bit, drill a pilot hole through the bed in this location.

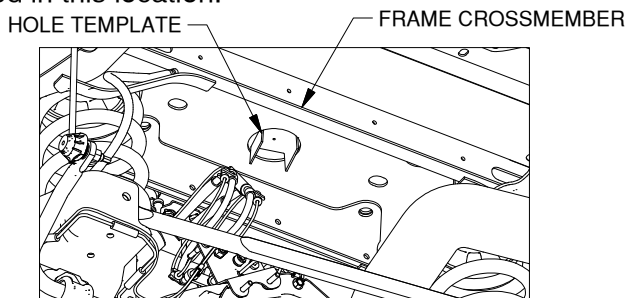

FIGURE A6: looking under truck bed towards cab.

9. **Cut the 3-1/2" diameter hole.** From the top side of the bed, use the pilot hole and a hole saw to create a 3-1/2" diameter hole in the truck bed floor. A saber saw equipped with a metal cutting blade may also be used if the 3-1/2" diameter circle is laid out on the bed floor around the center of the pilot hole. Remove any burrs created while cutting the hole. The size of the round portion of the hitch that will be seen from the truck bed was determined by the size of the hole in the truck's frame. The closest nominal hole size to this feature is 3-1/2". The 3-1/2" hole will leave a gap around the hitch structure. This gap will be filled in by the plastic spacer block.

INSTALL CENTER SECTION

⚠ Turnoverball hitch components are heavy and may be cumbersome to handle. Failure to use proper lifting techniques and caution when handling these items could result in serious injury.

⚠ Most trucks have fuel lines, brake lines, electrical wires or other vehicle systems located along the frame rails or in the general area where B&W Turnoverball hitches install. Carefully examine the locations of these systems before installation. Make certain that these are not damaged during positioning hitch components, drilling holes, or tightening fasteners. Damage to these systems may result in property damage, serious injury, or death.

1. **Place spacer block.** Position the plastic spacer block between the frame cross member and the bed as shown. See figure B1. Center the hole in the spacer block over the hole in the frame.

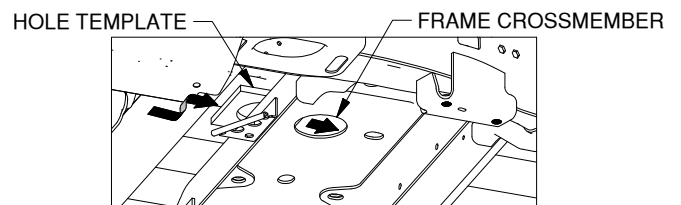

FIGURE B1: Looking up at bed from forward of the driver side tire.

2. **Install threaded blocks.** Place the threaded block, see figure B2, between the frame cross member and the bed, see figure B4. Use the handle welded to the blocks to guide them into place. Make sure that the two threaded holes in the blocks are directly over the holes in the frame, see figure B3.

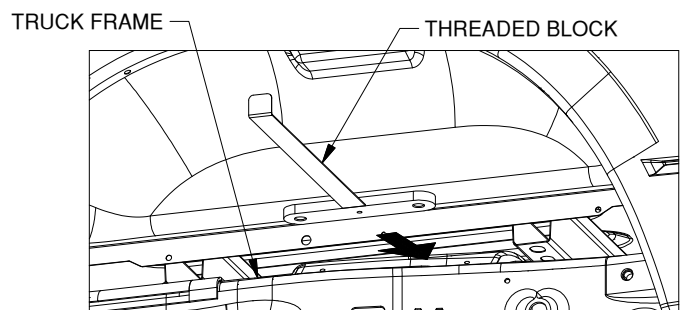
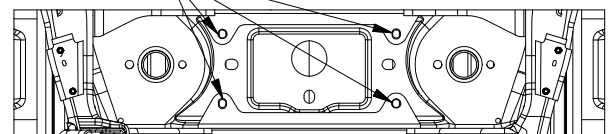
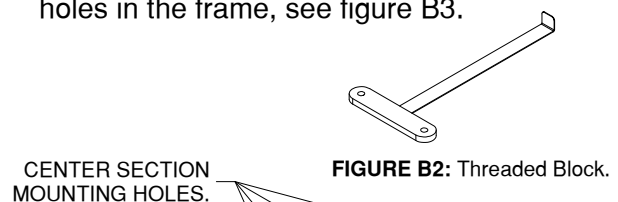

FIGURE B4: Looking at passenger side wheel well.

3. **Install the center section.** With the latch pin mechanism on the drivers side, raise the center section into place as shown, see figure B5. In order to clear structures under the truck bed, the center will have to be lifted into place on an angle over the exhaust, then positioned directly under the frame cross member so that the raised portion of the center can be pushed straight up through the hole in the frame cross member, and through the hole in the plastic spacer block. Having assistance in the bed to guide the top of the center section is recommended. Line the 4 holes in the center section up with the frame holes and the holes in the threaded blocks. Thread a 5/8 flange head bolt into each hole.

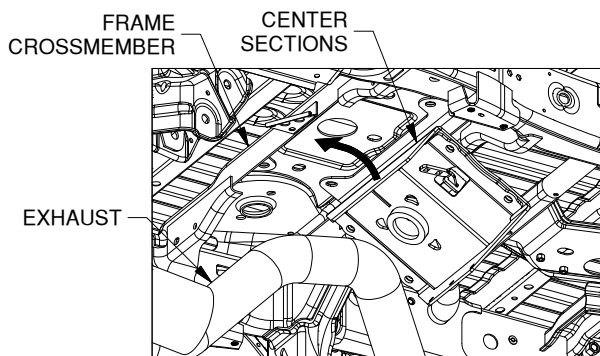

Figure B5: Looking up at the bed from forward of driver side tire.

SECURE HITCH

1. **Install safety chain bracket.** With the Center section loosely attached to the truck frame, locate and install the safety chain bracket by inserting the flange of the bracket with four holes between the bed crossmember and the frame crossmember and pushing up against the truckbed. Attach the safety chain bracket to the center section with three 1/2" x 1-1/2" bolts, 1/2" lock washers, and 1/2" nuts, as shown in figure C1. Do not fully tighten at this time.

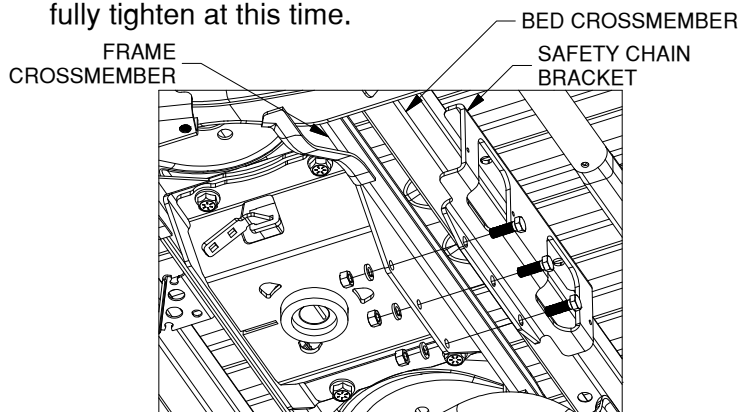

FIGURE C1: View looking up at center from under the truckbed.

2. **Square the hitch.** Using a tape measure, be sure that the full length of the gooseneck hitch is centered within the channel of the frame cross member. Do this by making sure that the gap between the center section and the frame cross member is the same on the driver and passenger sides. The hitch must not be touching the brake lines that are anchored to the frame cross member.

3. **Tighten the 5/8" bolts.** With the hitch square and firmly pressed against the frame cross member, tighten the 5/8" bolts. To better access the bolts on the passenger side of the center section the exhaust may be lowered to allow access to the bolts, see *preparing to install* section step 7. Torque the bolts to 100 ft. lbs.
4. **Tighten the Safety chain bracket bolts.** Tighten the three 1/2" bolts attaching the safety chain bracket to the center section. Torque the bolts to 80 ft. lbs.
5. **Disengage lifting device.** If a lifting device was used to hold the center section in place during the installation, remove it at this time.

INSTALL LATCH PIN HANDLE

1. **Install bolts.** Retract the latching mechanism by pulling on the tab with the square holes and pushing it toward the cab. From the top down, insert a 3/8 carriage bolt in each of the square holes in the latching mechanism, see figure D1.

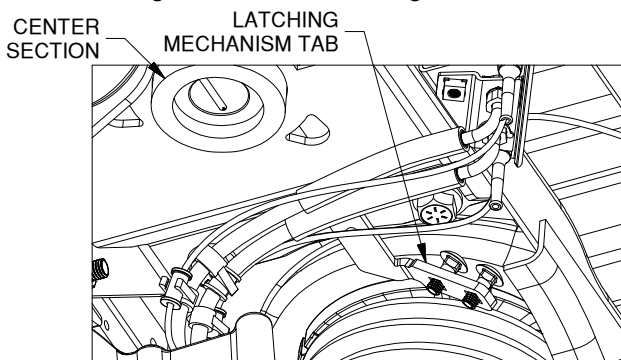

FIGURE D1: Looking up at center section

- ⚠ Serious injury can occur due to the pinch point located at the intersection of the latching mechanism and the center section.**

2. **Install the latch pin handle.** Beginning under the vehicle "thread" the end of the handle with the vinyl grip in front of the brake lines and over the frame on the drivers side. Attach the handle to the latching mechanism over the 3/8 carriage bolts with two 3/8 locking flange nuts, see figure D2. Be sure that the handle is in the proper position and that it does not interfere with any other components of the vehicle. Torque the nuts to 30 ft. lbs. to secure the handle.

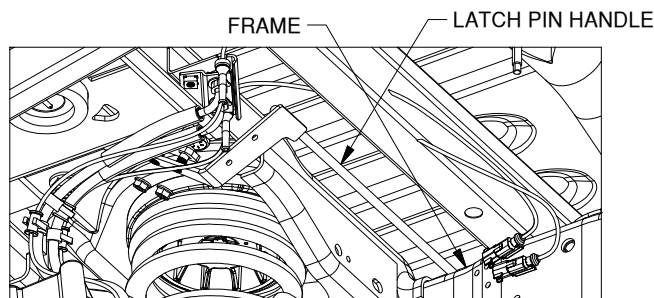

FIGURE D2: Looking back at driver side of center section.

Notice: The latch handle must be positioned on the "cab side" of the brake lines directly over the axle.

INSTALL SAFETY CHAIN U-BOLTS

1. **Drill the holes.** From under the bed, use a drill and a 9/16" drill bit to drill through the bed using the 9/16" holes in the safety chain bracket as a guide. *Due to truck geometry, the holes will need to be drilled at a slight angle.*
2. **Install the U-bolts.** From the top side of the truck bed, drop a U-bolt in each set of holes.
3. **Add springs.** Place a conical spring over each leg of the U-bolts and secure with a 1/2" lock nut, see figure E1. Tighten the lock nut until the nut is flush with the end of the U-bolt.

CENTER SECTION

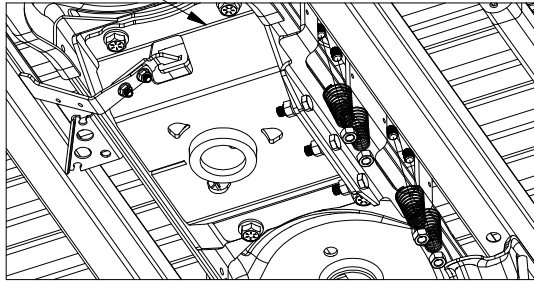

FIGURE E1: View looking up at center section.

INSTALL FRAME STICKER

1. **Place handle sticker.** Locate the latch handle sticker provided with your instruction packet. Apply the sticker to the frame in the driver side wheel well. Align the left edge of the sticker with the latch handle and top and bottom edges of the sticker with the frame.

PREPARE FOR TOWING

1. **Re-attach exhaust bracket.** If the exhaust was un-attached, Pull the exhaust back up to the exhaust bracket and re-attach. We recommend using soap and water to lubricate the "pin" and the rubber hanger which attach the exhaust hanger to aid in re-attachment.
2. **Replace spare tire and heatshield.** If the spare tire and/or the heatshield was removed prior to installing the hitch, replace it at this time.
3. **Modify fender liner.** If a fender liner is present that restricts the movement of the handle, it is recommended that it be modified by cutting a relief slot or hole to allow the handle to move freely. If the liner was removed for installation, reinstall at this time.
4. **Retract the pin.** Pull the handle out all the way until it stops then slide it toward the cab. The handle should stay in this position. The latch should only be put in this open position when inverting the 2-5/16" ball or installing a B&W towing accessory.

⚠ Operating the tow vehicle while the latch is in the open position may allow the handle to come into contact with the rear tire. This may damage the tire or the handle and could lead to serious injury or death.

5. **Lubricate 2-5/16" ball.** Apply a light coating of grease to the corners on the square shank of the 2-5/16" ball.
6. **Check latch pin engagement.** When installed properly, the latch pin mechanism should pass through both sides of the ball socket. With the ball removed, push handle toward the rear of the truck until the handle retracts and the latch pin engages. Visually inspect the ball socket and check to be sure the latch pin has passed completely through the socket. Make a mark on the latching mechanism where indicated in figure G1 to show where the latching mechanism should be when the pin is correctly positioned in the ball socket. Retract the pin, replace the ball, and re-engage the pin. Check the marked location on the latching mechanism. If the mark is in the same location as when the mark was made, then the latch pin has gone completely through the ball socket.

⚠ Failure of the pin to engage the ball and hitch properly could result in a loss of attachment between the trailer and the tow vehicle

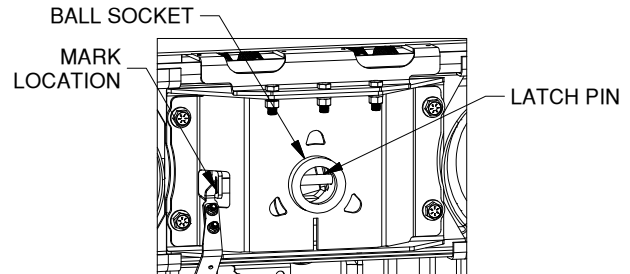

FIGURE G1: View under bed looking up at center section.

- Always be sure that latch pin is fully engaged in the socket before towing.
- Inspect hardware connections before towing to be sure that they are secure..
- Measure and determine turning clearance with cab before towing unfamiliar trailers. Additional products for increasing turning clearance are available from B&W.
- When inverting the ball, inspect the ball's relationship with the truck's differential and drive line to insure proper clearance. **DO NOT INVERT THE BALL WHEN HAULING HEAVY LOADS ON 2 WHEEL DRIVE TRUCKS.** A plug for the socket is available from B&W so that the ball may be removed and the socket may be covered when hauling heavy loads.
- Periodically grease the corners on the square shank of the 2-5/16" ball.