



TORKLIFT

I N T E R N A T I O N A L

**OVER 40 YEARS OF INNOVATION, QUALITY, SAFETY.
IMPORTANT OWNER-OPERATOR INSTALLATION INSTRUCTIONS**

N2410

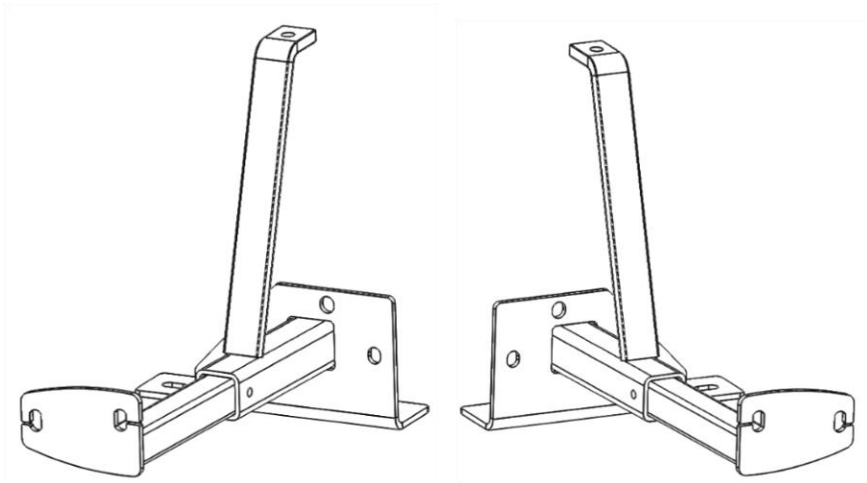

Version Number: 2, Date: 11/23/2016 By: CW

TECH SUPPORT (800) 246-8132

**AFTER INSTALL, PLEASE GIVE
THIS BOOKLET TO YOUR CUSTOMER**

Warnings

Truck Bed and Camper Protection

Torklift **does not** recommend installing your camper on top of a plastic bed liner (or other compressible material such as foam). These materials can act as a spring, causing increased vertical truck camper movement independent of the vehicle. Plastic bed liners can slide on the truck bed surface, and the truck camper can slide on top of the bed liner. Using a plastic bed liner or similar compressible material will void your warranty and may additionally cause truck bed and/or camper damage.









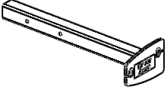

Minor movement or settling can occur in some incidental harsh driving conditions (on or off-road). A rubber bed mat is recommended to protect the truck bed and camper, but is not a requirement to maintain the Torklift legendary lifetime warranty.

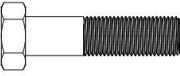
Suspension

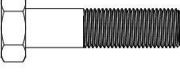

To significantly reduce body roll, sag and sway Torklift strongly recommends the StableLoad. Torklift International StableLoads improve safety, handling, and to help level your truck. More information can be found at (www.Torklift.com/stableload).

If your truck is additionally equipped with suspension air bags Torklift cautions against over pressurization as this may lead to unsafe vehicle handling characteristics. We have found that airbags used in conjunction with StableLoads have allowed operators to lower air bag pressure by 50% or more. Only pressurize suspension air bags enough to level the truck.

Parts Inventory

Item Image	Item Description	Quantity
	Front Tie Down Receiver	2
	17.875" Straight Tie Down Insert	2
	Bail Pin	2
	7/16"-14 x 2" Gr 5 - Hex Head Cap Screw	2
	7/16" - USS - Internal Star Washer	2
	7/16" - USS - Lock Washer	2
	7/16" - USS - Flat Washer	2
	7/16"-13 - Gr 5 - Hex Head Nut	2
	1/2"-13 x - 2" Gr 5 -Hex Head Cap Screw	4
	1/2" - USS - Star Washer	4
	1/2" - USS - Flat Washer	4
	1/2" - USS - Lock Washer	4

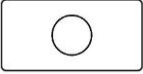
Parts Inventory

Item Image	Item Description	Quantity
	½"-13 x - Gr 5 - Hex Head Nut	4
	1" x 2" Plate Washer	6
	7/16" Bolt Fisher	1
	½" Bolt Fisher	2

Installation Notes:

Step 1:

Begin by placing the transmission in "Park" or chalking the tires. Once this has been completed, release the parking brake.

Step 2:

Identify location on frame where the front Driver side tie down will mount. This location is in front of the rear leaf spring. Remove the factory bed mount bolt and washer as seen in [figure 1] and set aside for later use.

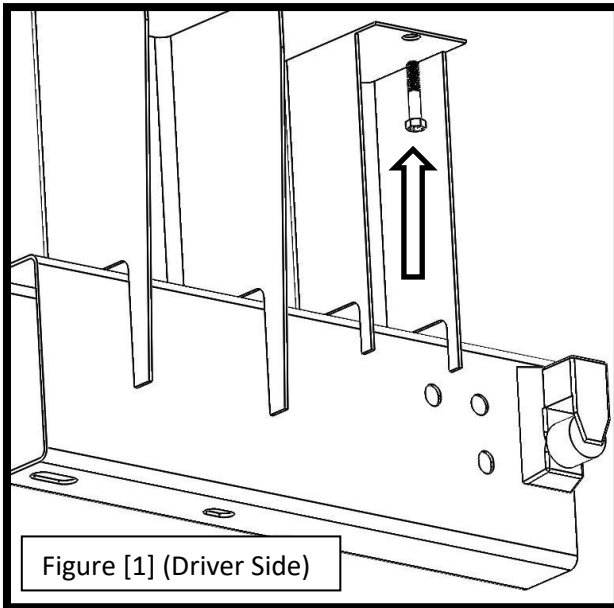

Step 3:

The fully mounted tie down will utilize holes B, C, D, and E. Holes B and D will use $\frac{1}{2}$ "-13 x - 2" Gr5 - Hex Head Cap Screw, hole C will use a $\frac{7}{16}$ "-13 - 2" Gr5 Hex Head Cap Screw, and hole E will use the factory bolt that was removed in step 2.

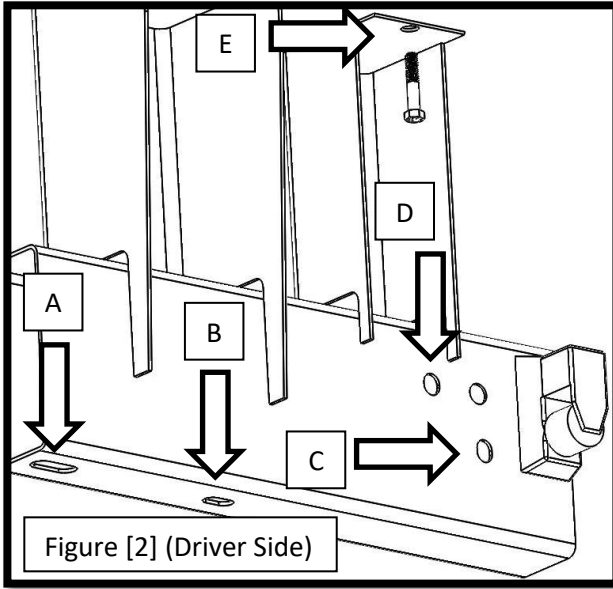

Insert the coiled end of a bolt fisher into hole C and guide it until it exits from Hole B. Without letting the straight end of the bolt fisher drop into the frame, attach the $\frac{7}{16}$ "-14 x 2" Gr5 - Hex Head Cap Screw with $\frac{7}{16}$ " internal lock washer and 1" X 2" plate washer to the coiled end [See figure 3]. Once attached to the bolt fisher, guide the assembly into the frame. This may require turning the washers to fit through the hole. Gently pull on the straight end of the bolt fisher until the bolt is protruding from hole C. Leave the bolt fisher attached.

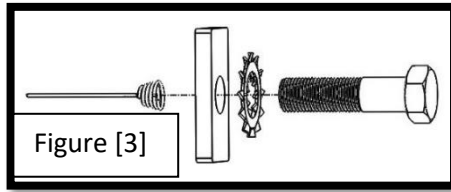

Repeat the same process to fish the next bolt from hole B to hole D. This hole will use one 1/2"-13 x - 2" Gr5 -Hex Head Cap Screw, one 1/2" internal lock washer, and one 1" X 2" plate washer. The end result will have the bolt protruding from hole D. Leave the bolt fisher attached.

Repeat the same process to fish the next bolt from hole B to hole A. This hole will use one 1/2"-13 x - 2" Gr5 -Hex Head Cap Screw, one 1/2" internal lock washer, and one 1" X 2" plate washer. The end result will have the bolt protruding from hole A. Leave the bolt fisher attached.

The setup should look like Figure 4. The bolt fishers should still be attached (not shown).

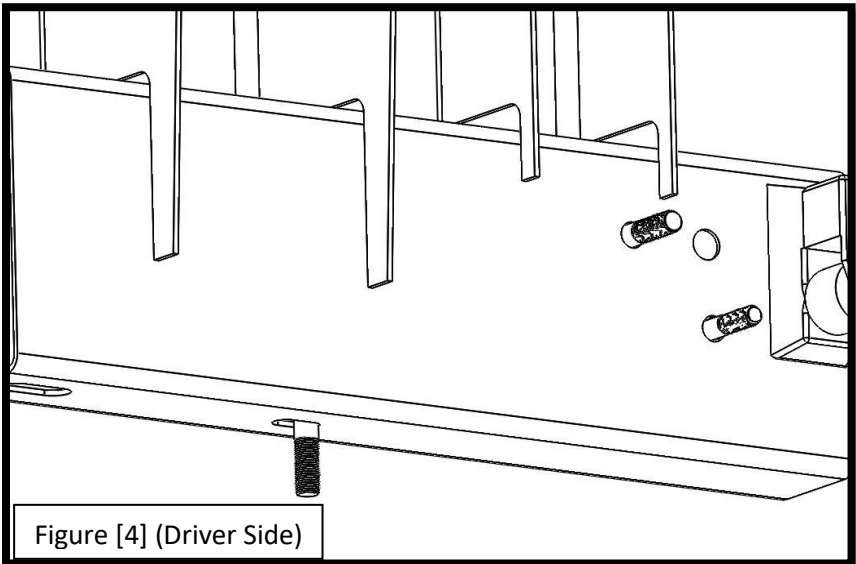

Gently push the screws back into the frame. Feed the free end of each bolt fisher through the corresponding tie down hole, then hold the tie down up against the frame. Pull the bolt fisher so the bolts are out of the frame and the tie down is in the correct position. See figure 5. The bolt fishers should still be attached (not shown).

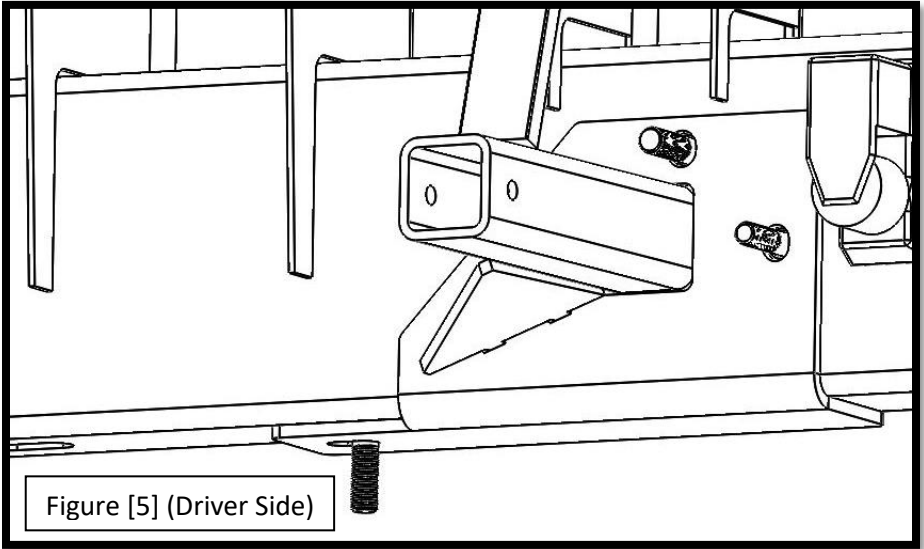

Keeping the tie down in position, hand tighten the factory bolt with the factory washers into hole E. This will hold the tie down in position to hand tighten the remaining bolts.

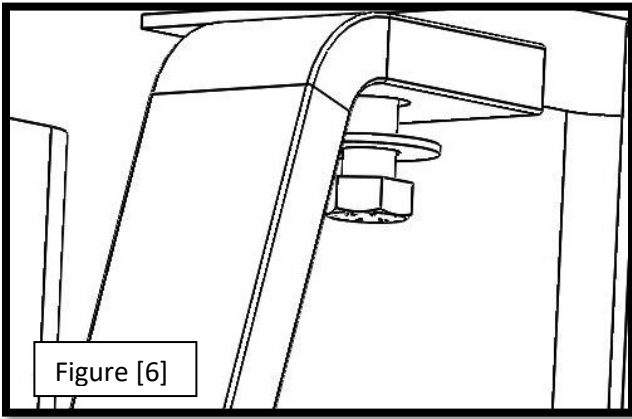

Remove the bolt fisher for the lower 1/2" bolt. Apply a small amount of sideways pressure with your hand to stop the bolt from pushing into the frame. Insert one 1/2" flat washer, one 1/2" lock washer, and one 1/2" nut and hand tighten. Repeat the process for the second 1/2" bolt.

Remove the bolt fisher for the 7/16" bolt. Apply a small amount of sideways pressure with your hand to stop the bolt from pushing into the frame. Insert one 7/16" flat washer, one 1/16" lock washer, and one 7/16" nut and hand tighten.

Once all nuts are hand tight, torque according the chart below.

Bolt Size	Torque (ft-lbs)
1/2	70
7/16	45
Factory Bolt	27

The end result is a fully attached Tie down as seen in figure 7. Repeat the installation process for the passenger side of the vehicle.

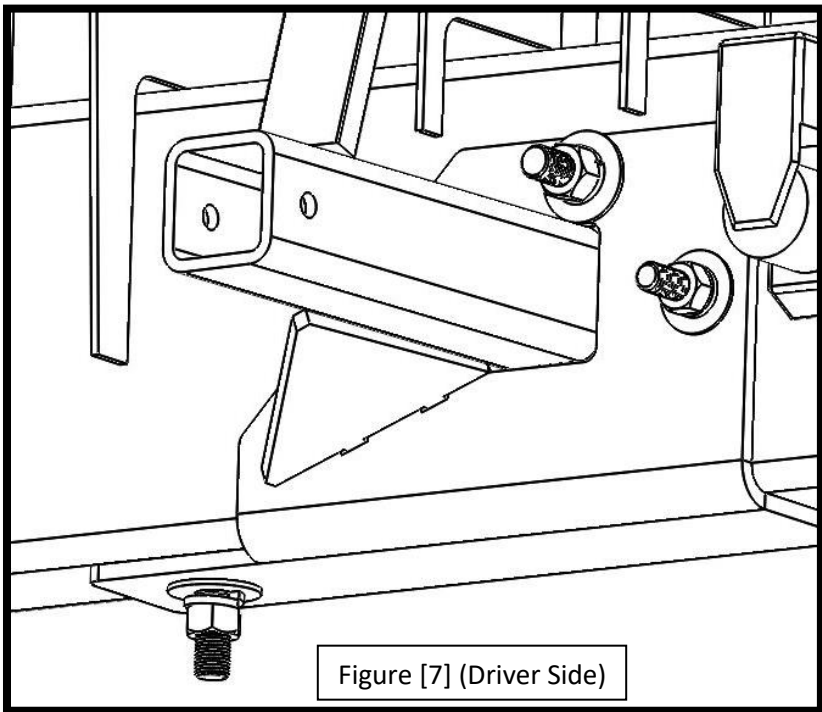

Figure [7] (Driver Side)

TIEDOWN INSERT INSTALLATION INSTRUCTIONS

On one end of each of your tie down inserts is a triangular plate referred to by Torklift as a bullet plate. In most cases, the tie down inserts should be installed with the shorter side of the bullet plate facing away from each other (The shorter side of the front insert should point to the front of the truck and the shorter side of the rear insert should point towards the rear of the truck).



DRIVERS SIDE FRONT



DRIVERS SIDE REAR

Once installed, attach the TorkLift directional stickers to the face of the bullet plate on the insert as a reminder.

IMPORTANT NOTE: Your tie down inserts are designed to have clearance inside of the receiver. This is to account for road debris, as well as aid in installation and removal. Some rattle may be expected if the inserts are left installed while not under load from the camper.

Torklift International Limited Lifetime

Warranty Information

322 Railroad Ave North, Kent, WA 98032

Torklift will require proof of purchase to register, with pictures of any defective product before issuing a replacement. Torklift will not register any product without proof of purchase, which can be faxed, scanned, emailed, or mailed to the information provided below. Torklift warrants its hitches, custom hitch receivers, frame mounted tie downs, turnbuckles, and accessories (excluding wire harnesses which carry a 90 day warranty) from date of purchase against defects in material and workmanship under normal use and service for the ownership life of the original consumer purchaser. All plastic, rubber, and/ or electrical components maintain a warranty of up to one year from the date of the purchase. **ALL COMMERCIAL APPLICATIONS ARE WARRANTED FOR A PERIOD OF 90 DAYS FROM THE DATE OF INSTALLATION/SERVICE.** Torklift will replace **FREE OF CHARGE** any part which proves defective in material or workmanship when presented to Torklift, **TRANSPORTATION CHARGES PREPAID** by purchaser, at the address above. **THIS WARRANTY IS LIMITED TO DEFECTIVE PARTS REPLACEMENT ONLY. LABOR CHARGES AND/OR DAMAGE INCURRED IN INSTALLATION OR REPLACEMENT, AS WELL AS INCIDENTAL AND CONSEQUENTIAL DAMAGES CONNECTED THEREWITH ARE EXCLUDED.** This warranty does not include the finish or paint on our products. Rusting, cracking or peeling of the finish is also excluded. Some states do not allow the exclusion or limitation of incidental or consequential damages, so the above limitation or exclusion may not apply to you. Any damage to Torklift products as a result of misuse, abuse, neglect, accident, improper installation or any use violation of instructions furnished by Torklift or **WHEN USED IN ANY COMMERCIAL APPLICATION WILL VOID THE WARRANTY.** This warranty gives you specific legal rights, and you may also have rights which vary from state to state. With warranty service, you may be able to go to a small claims court, a state court or a federal district court.



TORKLIFT™

INTERNATIONAL

322 Railroad Ave North, Kent, WA 98032

Phone (800) 246-8132 Fax (253) 854-8003

Or visit our website: www.TorkLift.com

Dear Valued Customer,

Thank you for making TorkLift your choice for truck, camper packages and accessories for your vehicle. By choosing TorkLift products, you have chosen a company that has been serving the RV industry for nearly 40 years and whose name has become synonymous with strength, quality and advanced design and installation.

Please take a few moments of your time to complete the Product Registration Warranty Card on the next page. When registering your newly purchased TorkLift products, you can be assured that your contact information is secure and that you and your product are getting the attention and respect that you deserve.

Thank you again for choosing TorkLift quality products.

Register for your lifetime warranty and receive a free Torklift International gift.

To Fax: Send copies of the questionnaire, warranty card and receipt to
253-854-8003

To E-mail: Send copies of the questionnaire, warranty card and receipt to
warranty@torklift.com

To Mail: Send to Torklift International 322 Railroad Ave North, Kent, WA 98032



OFFICIAL WARRANTY REGISTRATION CARD

322 Railroad Ave North, Kent, Wa 98032

Please fill out this form completely and return to Torklift within 30 days of purchase accompanied by a copy of your original receipt

1. PART(S) PURCHASED

TODAY'S DATE: _____

PART#: _____ PART#: _____
PART#: _____ PART#: _____
PART#: _____ PART#: _____

2. PURCHASER INFORMATION

NAME: _____
ADDRESS: _____

CITY: _____ STATE: _____ ZIP / POSTAL CODE: _____
PHONE: (_____) - _____ EMAIL: _____

3. TRUCK INFORMATION

YEAR: _____ MAKE: _____
MODEL: _____ BED LENGTH: _____

4. CAMPER INFORMATION

YEAR: _____ MAKE: _____ MODEL: _____

5. DEALER INFORMATION

PURCHASED FROM: _____
ADDRESS: _____
CITY: _____ STATE: _____ ZIP / POSTAL: _____
INSTALLED BY: OWNER ABOVE DEALER ANOTHER DEALER

IF ANOTHER DEALER, WHO: _____