

TORKLIFT **INTERNATIONAL**

**OVER 40 YEARS OF INNOVATION, QUALITY, SAFETY.
IMPORTANT OWNER-OPERATOR INSTALLATION INSTRUCTIONS**

T2310

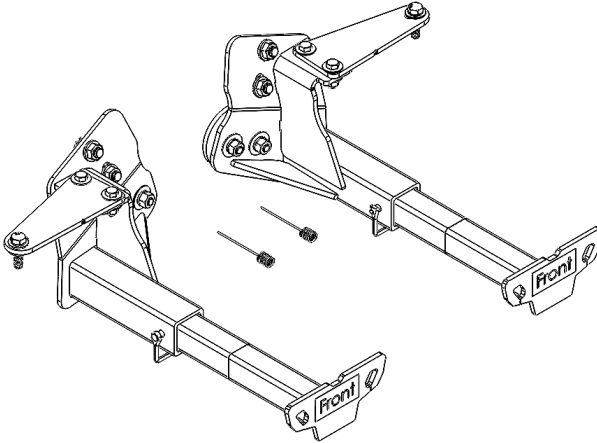

Version Number: 2, Date: 6/25/2020 By: QT

TECH SUPPORT (800) 246-8132

**AFTER INSTALL, PLEASE GIVE
THIS BOOKLET TO YOUR CUSTOMER**

Warnings

Truck Bed and Camper Protection

Torklift **does not** recommend installing your camper on top of a plastic bed liner (or other compressible material such as foam). These materials can act as a spring, causing increased vertical truck camper movement independent of the vehicle. Plastic bed liners can slide on the truck bed surface, and the truck camper can slide on top of the bed liner. Using a plastic bed liner or similar compressible material will void your warranty and may additionally cause truck bed and/or camper damage.









Minor movement or settling can occur in some incidental harsh driving conditions (on or off-road). A rubber bed mat is recommended to protect the truck bed and camper, but is not a requirement to maintain the Torklift legendary lifetime warranty.

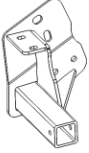

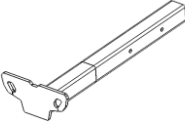
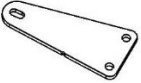

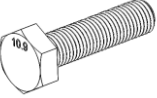

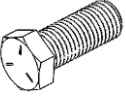



Suspension

To significantly reduce body roll, sag and sway Torklift strongly recommends the StableLoad. Torklift International StableLoads improve safety, handling, and to help level your truck. More information can be found at (www.Torklift.com/stableload).

If your truck is additionally equipped with suspension air bags Torklift cautions against over pressurization as this may lead to unsafe vehicle handling characteristics. We have found that airbags used in conjunction with StableLoads have allowed operators to lower air bag pressure by 50% or more. Only pressurize suspension air bags enough to level the truck.

Parts Inventory

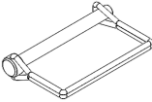
Item Image	Item Description	Item #	Qty.
	Driver Side Tie Down Receiver	T2310-W1-D	1
	Passenger Side Tie Down Receiver	T2310-W1-P	1
	17-7/8" Straight tie Down Insert (Driver and Passenger)	TD-INS-MS-W12	2
	Horizontal Gusset Plate	T2310-P5	2
	Keeper Plate	T2310-W2	2
	M10-1.25 x 40mm Hex Bolt – Class 10.9	12008	2
	M10 Split Lock Washer	12009	2
	1/2"-13 x 1-1/4" - Hex Bolt - Grade 5	7321	4
	1/2"-13 – Flanged Hex Nut - Grade 5	7181	4

	1/2" Star Washer	4566	4
	1/2" SAE Flat Washer	7465	4
	3/8"-16 x 1-1/4" - Hex Bolt - Grade 5	4627	4
	3/8"-16 - Hex Nut - Grade 5	3306	4
	3/8" USS Flat Washer	6001	10
	3/8" Split Lock Washer	6003	4
	7/16"-14 - Hex Nut - Grade 8	9962	4
	7/16" Split Lock Washer	3311	4
	7/16" USS Flat Washer	3536	4
	1/4" x 2-1/4" Bail Pin	1452	2
	1/2" Bolt Fisher	3818	2
	Front Insert Sticker	13779	2

Installation Notes:

Step 1:

- Loosen and remove the top rear-most M10-1.25 factory bolt in the cab mount as shown in figure 1.1 and 1.2.

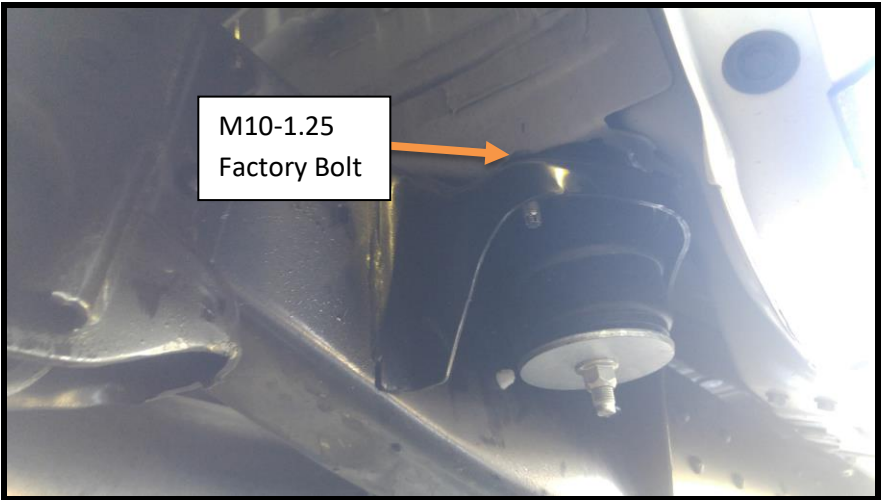

Figure 1.1 (Passenger Side)

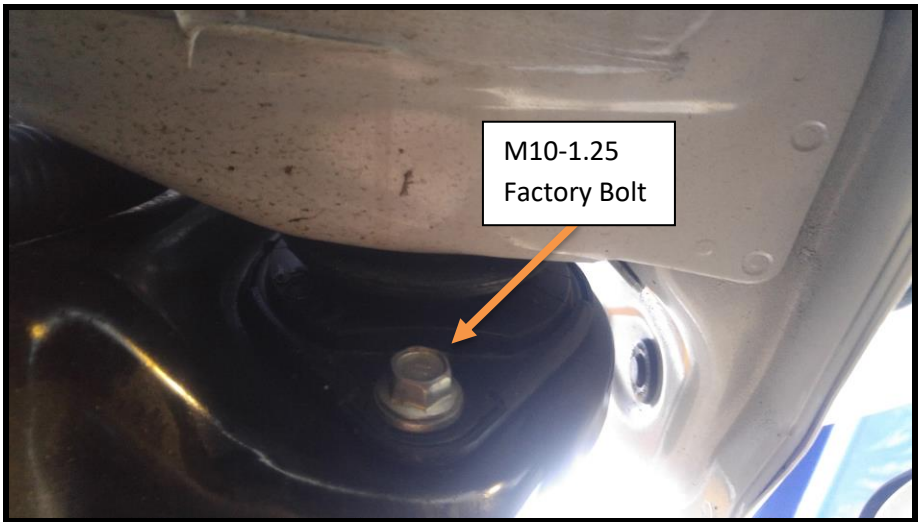

Figure 1.2 (Passenger Side)

Step 2:

- Locate the front Spring Perch under the bed. Using the 1/2" Bolt Fisher, insert the coiled end through the lower hole just above the Spring Bolt.
- Guide the bolt fisher through the square hole in the frame and out the bottom.
- Place one 1/2" Star Washer on a 1/2"-13 x 1-1/4" Hex Bolt, then thread the bolt onto the end of the bolt fisher.
- Use the straight end of the bolt fisher to pull the hardware back through the frame and out the original hole. Leave the bolt fisher attached.
- Repeat this process for the hole directly above as shown in Figure 2.1.



Figure 2.1 (Passenger Side Shown)

Step 3:

- Slide Keeper Plate up into the cavity by the leaf spring hanger bolt as shown in figure 3.1.
- Rotate the plate so that it is captured as shown in figure 3.2.



Figure 3.1 (Passenger Side Shown)



Figure 3.2 (Passenger Side Shown)

Step 4:

- Slide and align the Passenger Side Tiedown Receiver over all the bolts and loosely secure using two 1/2"-13 flanged Hex Nuts on top.
- Secure each Keeper Plate stud with a 7/16" USS Flat Washer, 7/16" Split Lock washer and 7/16"-14 Hex Nut as shown in Figure 4.1 and 4.2.

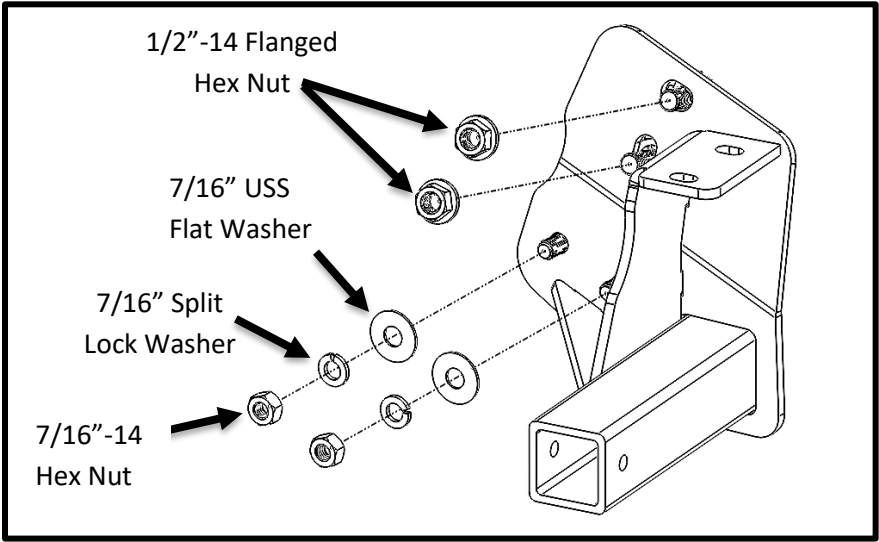

Figure 4.1 (Passenger Side Shown)



Figure 4.2 (Passenger Side Shown)

Step 5:

- Place the Horizontal Gusset Plate with the notch facing away from the truck. Add up to two 1/2" SAE Flat Washers on top of the cab mount bolt hole that was removed in step one.
- Thread in a M10-1.25 x 40mm Hex Bolt with one M10 Split Lock Washer and one 3/8" USS Flat Washer into the cab mount as shown in figure 5.1.

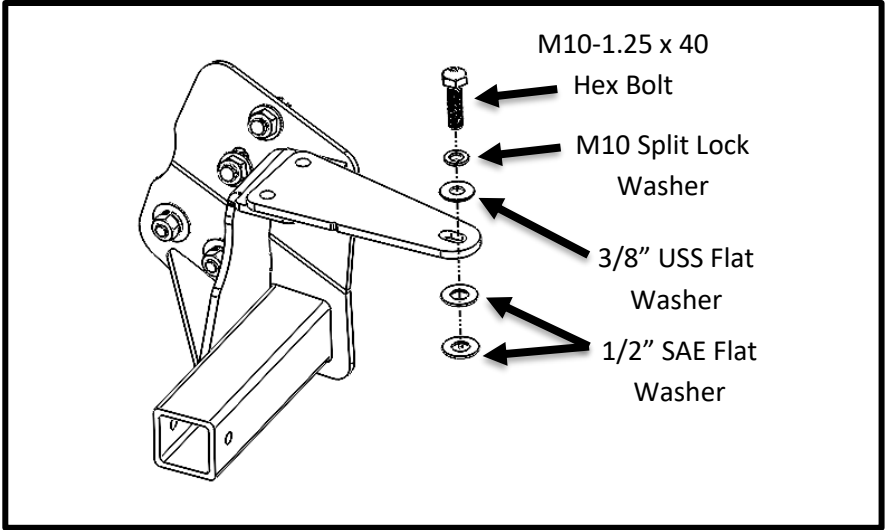

Figure 5.1 (Cab Mount Not Shown for Clarity)

- Loosely secure the Horizontal Gusset Plate to the Passenger Side Tiedown Receiver with one 3/8"-16 x 1-1/4" Hex Bolt, two 3/8" USS flat washers, one 3/8" Split Lock Washer and one 3/8"-16 Hex Nut per hole as shown in figure 5.2.

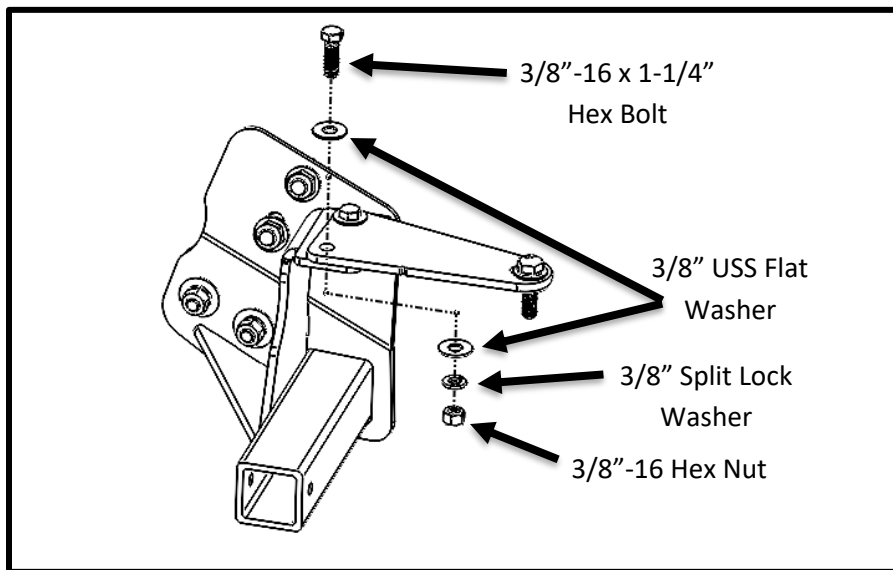

Figure 5.2 (Passenger Side, Frame Not Shown for Clarity)

Step 6:

- Torque the hardware in the order shown.
 - Horizontal Gusset Plate M10-1.25 Hex bolt 30 ft-lbs. (41nm)
 - Horizontal Gusset Plate 3/8" hardware 25 ft-lbs. (34nm)
 - 1/2" and 7/16" Receiver hardware 50 ft-lbs. (68nm)

Step 7:

- Install one of the Tie Down Inserts into the Passenger Side Tie Down Receiver. Either hole in the Tie Down Insert can be used if it provides sufficient clearance between the turn buckle and vehicle body.
- Secure the Tie Down Insert with the 1/4" Bail Pin.
- Apply sticker to the Tie Down Insert. See Figure 7.1.

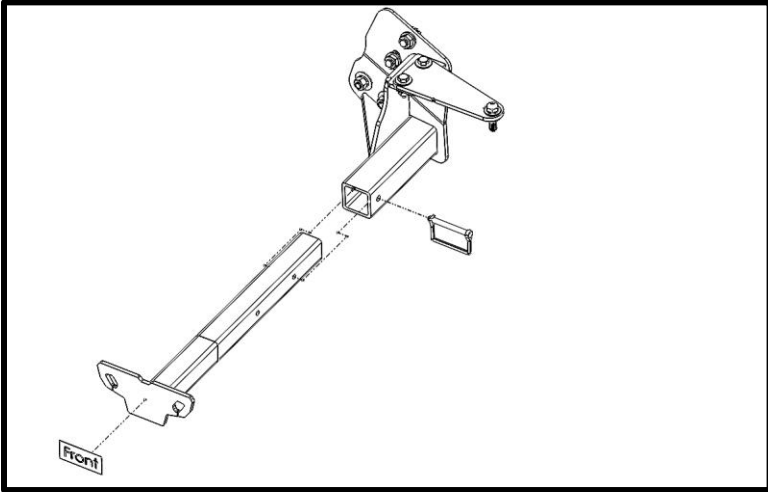

Figure 7.1

Step 8:

- Repeat Step 1-7 on driver side of the vehicle.
- Temporarily remove the hose bracket shown in figure 8.1 if needed. Replace when finished.

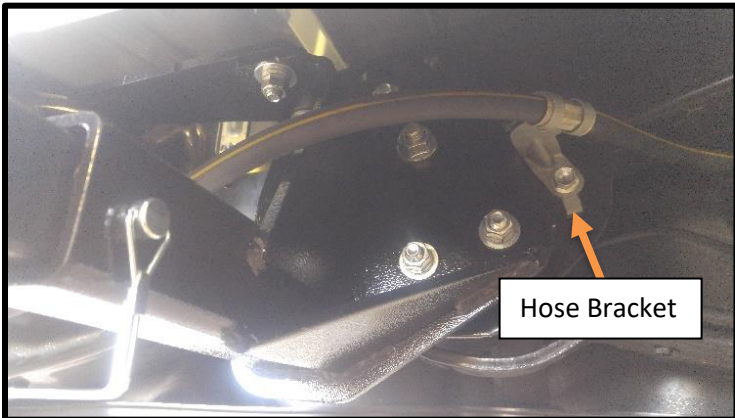

Figure 8.1

Torklift International Limited Lifetime

Warranty Information

322 Railroad Ave North, Kent, WA 98032

Torklift will require proof of purchase to register, with pictures of any defective product before issuing a replacement. Torklift will not register any product without proof of purchase, which can be faxed, scanned, emailed, or mailed to the information provided below. Torklift warrants its hitches, custom hitch receivers, frame mounted tie downs, turnbuckles, and accessories (excluding wire harnesses which carry a 90 day warranty) from date of purchase against defects in material and workmanship under normal use and service for the ownership life of the original consumer purchaser. All plastic, rubber, and/ or electrical components maintain a warranty of up to one year from the date of the purchase. **ALL COMMERCIAL APPLICATIONS ARE WARRANTED FOR A PERIOD OF 90 DAYS FROM THE DATE OF INSTALLATION/SERVICE.** Torklift will replace **FREE OF CHARGE** any part which proves defective in material or workmanship when presented to Torklift, **TRANSPORTATION CHARGES PREPAID** by purchaser, at the address above. **THIS WARRANTY IS LIMITED TO DEFECTIVE PARTS REPLACEMENT ONLY. LABOR CHARGES AND/OR DAMAGE INCURRED IN INSTALLATION OR REPLACEMENT, AS WELL AS INCIDENTAL AND CONSEQUENTIAL DAMAGES CONNECTED THEREWITH ARE EXCLUDED.** This warranty does not include the finish or paint on our products. Rusting, cracking or peeling of the finish is also excluded. Some states do not allow the exclusion or limitation of incidental or consequential damages, so the above limitation or exclusion may not apply to you. Any damage to Torklift products as a result of misuse, abuse, neglect, accident, improper installation or any use violation of instructions furnished by Torklift or **WHEN USED IN ANY COMMERCIAL APPLICATION WILL VOID THE WARRANTY.** This warranty gives you specific legal rights, and you may also have rights which vary from state to state. With warranty service, you may be able to go to a small claims court, a state court or a federal district court.



TORKLIFT™

INTERNATIONAL

322 Railroad Ave North, Kent, WA 98032

Phone (800) 246-8132 Fax (253) 854-8003

Or visit our website: www.TorkLift.com

Dear Valued Customer,

Thank you for making TorkLift your choice for truck, camper packages and accessories for your vehicle. By choosing TorkLift products, you have chosen a company that has been serving the RV industry for nearly 40 years and whose name has become synonymous with strength, quality and advanced design and installation.

Please take a few moments of your time to complete the Product Registration Warranty Card on the next page. When registering your newly purchased TorkLift products, you can be assured that your contact information is secure and that you and your product are getting the attention and respect that you deserve.

Thank you again for choosing TorkLift quality products.

Register for your lifetime warranty and receive a free Torklift International gift.

To Fax: Send copies of the questionnaire, warranty card and receipt to
253-854-8003

To E-mail: Send copies of the questionnaire, warranty card and receipt to
warranty@torklift.com

To Mail: Send to Torklift International 322 Railroad Ave North, Kent, WA 98032



OFFICIAL WARRANTY REGISTRATION CARD

322 Railroad Ave North, Kent, Wa 98032

Please fill out this form completely and return to Torklift within 30 days of purchase accompanied by a copy of your original receipt

1. PART(S) PURCHASED

TODAY'S DATE: _____

PART#: _____ PART#: _____

PART#: _____ PART#: _____

PART#: _____ PART#: _____

2. PURCHASER INFORMATION

NAME: _____

ADDRESS: _____

CITY: _____ STATE: _____ ZIP / POSTAL CODE: _____

PHONE: (____) _____ - _____ EMAIL: _____

3. TRUCK INFORMATION

YEAR: _____ MAKE: _____

MODEL: _____ BED LENGTH: _____

4. CAMPER INFORMATION

YEAR: _____ MAKE: _____ MODEL: _____

5. DEALER INFORMATION

PURCHASED FROM: _____

ADDRESS: _____

CITY: _____ STATE: _____ ZIP / POSTAL: _____

INSTALLED BY: _____ OWNER ABOVE DEALER ANOTHER DEALER

IF ANOTHER DEALER, WHO: _____