

# **TORKLIFT** **INTERNATIONAL**

**OVER 40 YEARS OF INNOVATION, QUALITY, SAFETY.  
IMPORTANT OWNER-OPERATOR INSTALLATION INSTRUCTIONS**

## **T2312**

**2022+ Toyota Tundra Front Tie Downs**

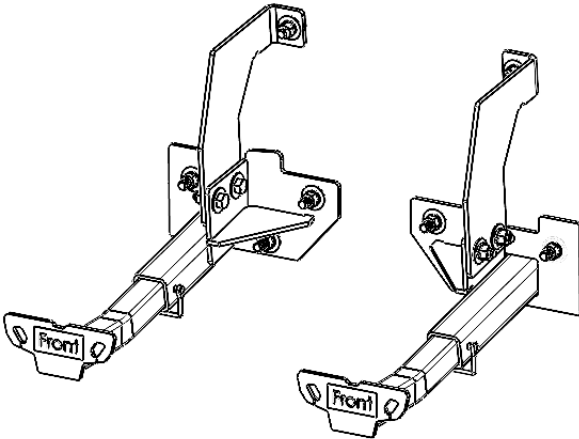

Version Number: 1, Date: 8/26/2022 By: CW

**TECH SUPPORT (800) 246-8132**

**AFTER INSTALL, PLEASE GIVE  
THIS BOOKLET TO YOUR CUSTOMER**

# Warnings

## Truck Bed and Camper Protection

Torklift **does not** recommend installing your camper on top of a plastic bed liner (or other compressible material such as foam). These materials can act as a spring, causing increased vertical truck camper movement independent of the vehicle. Plastic bed liners can slide on the truck bed surface, and the truck camper can slide on top of the bed liner. Using a plastic bed liner or similar compressible material will void your warranty and may additionally cause truck bed and/or camper damage.









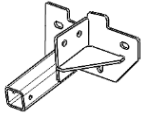
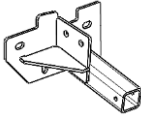

Minor movement or settling can occur in some incidental harsh driving conditions (on or off-road). A rubber bed mat is recommended to protect the truck bed and camper, but is not a requirement to maintain the Torklift legendary lifetime warranty.

## Suspension

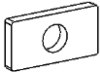
To significantly reduce body roll, sag and sway Torklift strongly recommends the StableLoad. Torklift International StableLoads improve safety, handling, and to help level your truck. More information can be found at ([www.Torklift.com/stableload](http://www.Torklift.com/stableload)).

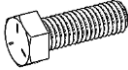
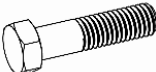
If your truck is additionally equipped with suspension air bags Torklift cautions against over pressurization as this may lead to unsafe vehicle handling characteristics. We have found that airbags used in conjunction with StableLoads have allowed operators to lower air bag pressure by 50% or more. Only pressurize suspension air bags enough to level the truck.

## Parts Inventory

Item Image	Item Description	Item #	QTY
	Driver Side Receiver	T2312-W1-D	1
	Passenger Side Receiver	T2312-W1-P	1
	Driver Side Gusset	T2312-P4-D	1
	Passenger Side Gusset	T2312-P4-P	1
	17-7/8" Bent Tie Down Insert	TD-INS-MS-W11	2
	1" x 2" Plate Washer	TL-HW-PW-P1	6
	1/2" Internal Tooth Lock Washer	14084	6
	1/2"-13 x 1-1/2" Grade 8 Hex Bolt	9960	6
	1/2"-13 x 2" Grade 8 Hex Bolt	3659	6
	1/2" USS Flat Washer	6039	22
	1/2" Split Lock Washer	9302	12
	1/2"-13 Grade 8 Hex Nut	1751	12
	1/4" x 2-1/4" Bain Pin	1452	2
	Front Insert Sticker	13779	2

## Step 1:

- Remove the three plastic plugs from the frame on the driver's side of the truck frame using a flat blade screwdriver or small pry tool (See A,B,C in Figure 1.1).

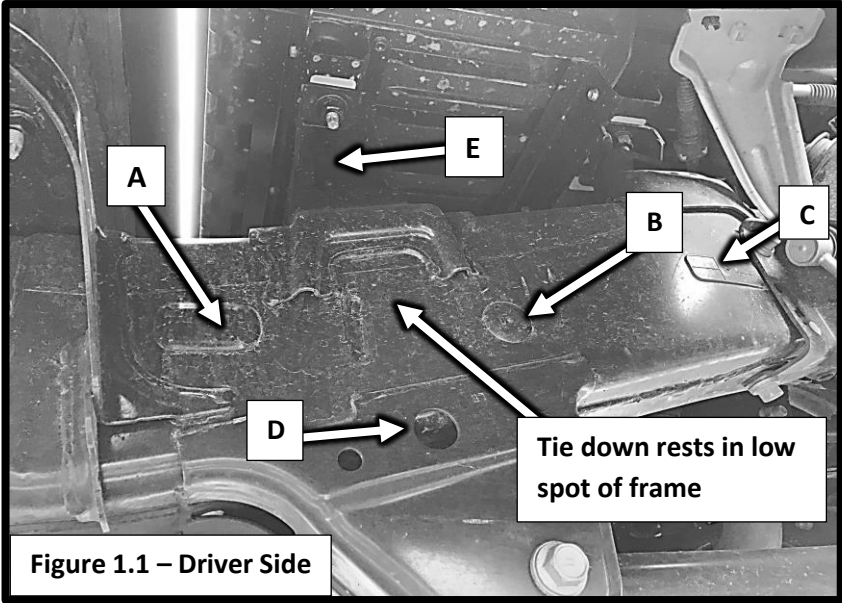

## Step 2:

- Place a 1/2" Internal Tooth lock Washer, then a 1" x 2" Plate Washer over the threads of a 1/2" x 2" Grade 8 Hex Bolt.
- Thread the coiled end of a bolt fisher onto the threads (See Figure 2.1)
- Insert the hardware into Hole A, then pull on the straight end of the bolt fisher until the threads of the bolt protrude back out the same hole (See Figure 2.2).
- Leave the bolt fisher attached.

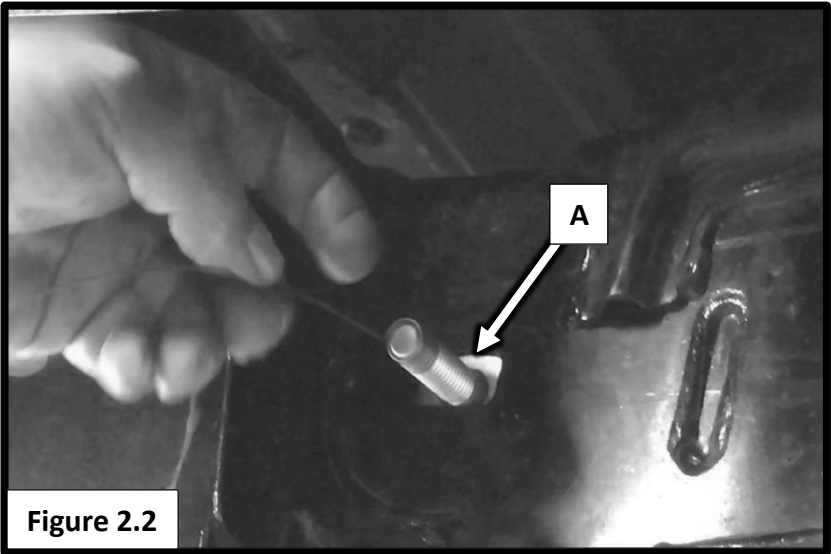
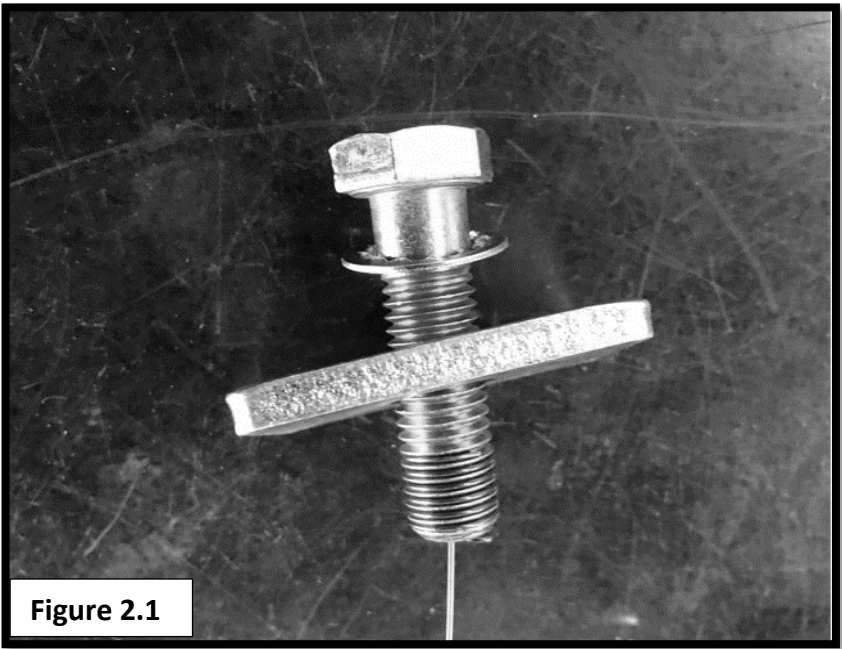

### Step 3:

- Insert the coiled end of another bolt fisher into hole B and guide it out through hole C (See Figure 3.1). Do not allow the straight end of the bolt fisher to fall into the frame.
- Place a 1/2" Internal Tooth lock Washer, then a 1" x 2" Plate Washer over the threads of a 1/2" x 2" Grade 8 Hex Bolt.
- Thread the bolt into the coiled end of the bolt fisher (See Figure 2.1)
- Insert the hardware into Hole C, then pull on the straight end of the bolt fisher until the threads of the bolt protrude from Hole B.
- Leave the bolt fisher attached.

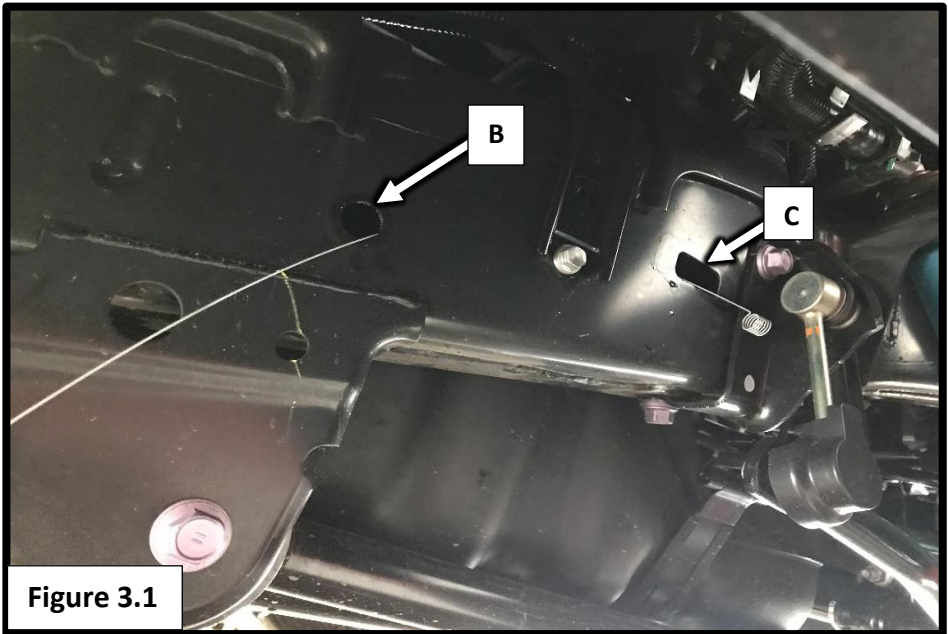

## Step 4:

- Place a 1/2" USS Flat washer over each bolt (See Figure 4.1)
- Insert the straight end of each bolt fisher through the appropriate hole in the Driver Side Tie Down Receiver.

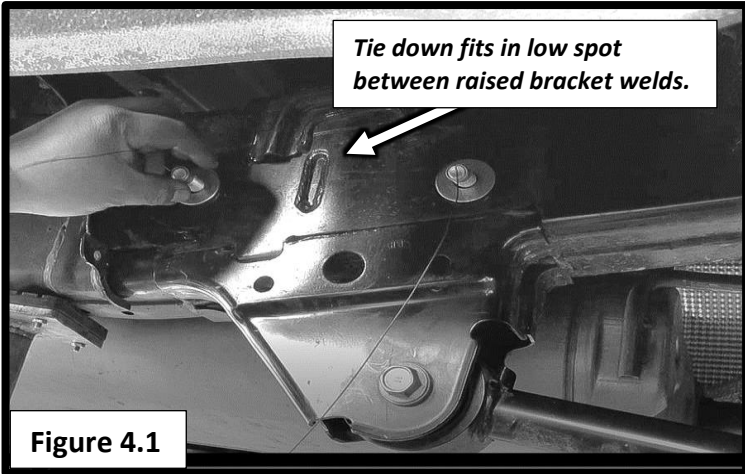

- Place the tie down receiver up against the frame, using the straight end of the bolt fishers to keep the bolts from falling back inside the frame (See Figure 4.2).

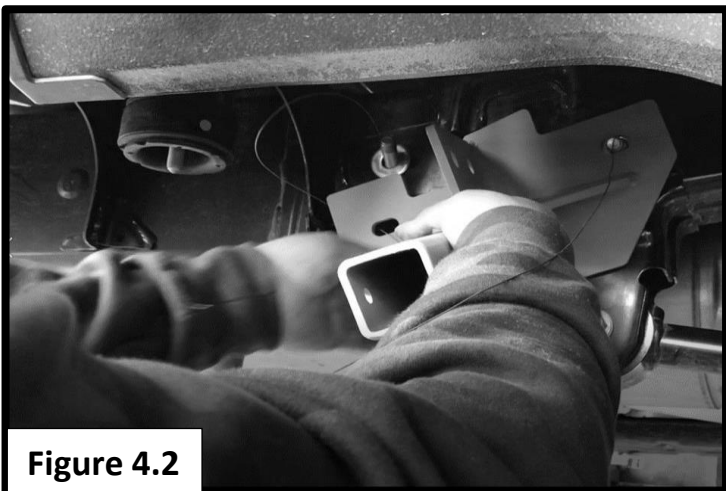

## Step 4 Continued:

- While holding the Tie Down Receiver against the frame, remove the bolt fisher from one of the bolts. Do not allow the bolt to fall back into the frame.
- Secure the bolt with one 1/2" USS Flat Washer, one 1/2" Split Lock Washer, and a 1/2"-13 Grade 8 Hex Nut. Leave the nut finger tight.
- Repeat for the process for the remaining bolt.

## Step 5:

- Insert the coiled end of a bolt fisher into Hole D in the tie down receiver and out through the rear of the control arm bracket (See Figure 5.1)



- Place a 1/2" Internal Tooth lock Washer, then a 1" x 2" Plate Washer over the threads of a 1/2" x 2" Grade 8 Hex Bolt.
- Thread the bolt into the coiled end of the bolt fisher.
- Pull on the straight end of the bolt fisher until the threads of the bolt protrude out through the tie down receiver.

## Step 5 Continued:

- Remove the bolt fisher, then secure the bolt with one 1/2" USS Flat Washer, one 1/2" Split Lock Washer, and a 1/2"-13 Grade 8 Hex Nut. Leave the hardware finger tight.

## Step 6:

- Insert a 1/2"-13 x 1-1/2" Grade 8 Hex Bolt through a 1/2" USS Flat washer, the upper hole of the Driver Side Gusset, and Hole E in the truck frame (See Figure 6.1). Note: When installing the passenger side, a wire harness retaining clip may interfere with the Passenger Side Gusset and will need to be disconnected by prying it out with a screw driver or pry tool.
- Secure the bolt to the truck frame with a 1/2" USS Flat Washer, a 1/2" Split Lock Washer, and a 1/2"-13 Grade 8 Hex Nut. Leave the hardware loose.
- Align the lower holes in the Driver Side Gusset and the Tie Down Receiver.
- Install one 1/2"-13 x 1-1/2" Grade 8 Hex Bolt with one 1/2" USS Flat Washer through each of the two holes.
- Secure each bolt with one 1/2" USS Flat Washer, one 1/2" Split Lock Washer, and a 1/2"-13 Grade 8 Hex Nut.

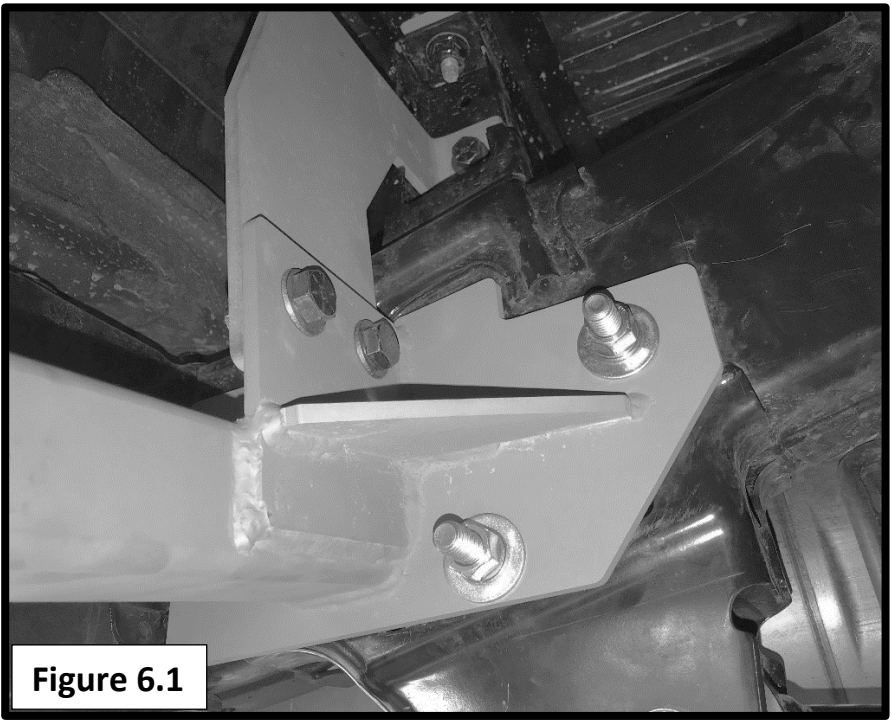

## Step 7:

- Beginning with the bolts in the frame, Torque all 1/2" hardware to 75 ft-lbs.
- Reinstall the factory plastic plugs into frame hole C.
- Repeat Steps 1-7 for the passenger side of the vehicle.

**Step 8:** Insert one of the tie down inserts into each receiver.

- Pin the inserts in place with a 2-1/4" bail pin. Either hole in the insert can be used. We recommend at least 1" (25mm) of clearance between the body and turnbuckles when setup.
- Place a front insert sticker onto the face of each insert. See Figure 8.1.

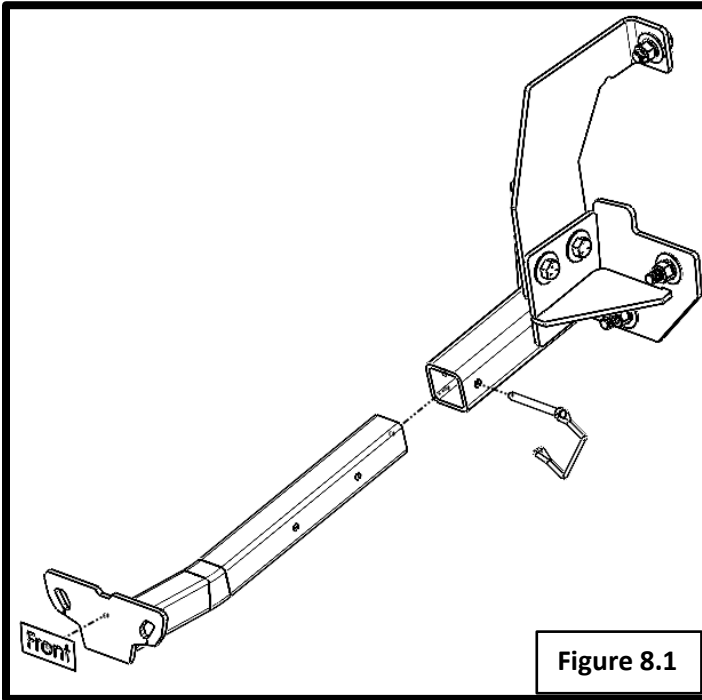

**Figure 8.1**

**IMPORTANT NOTE:** *Your tie down inserts were designed to have clearance inside of the receiver. This is to account for road debris, as well as aid in installation and removal. Some rattle may be expected if the inserts are left installed while not under load from the camper.*

**Installation is complete.**

# **Torklift International Limited Lifetime**

## **Warranty Information**

322 Railroad Ave North, Kent, WA 98032

Torklift will require proof of purchase to register, with pictures of any defective product before issuing a replacement. Torklift will not register any product without proof of purchase, which can be faxed, scanned, emailed, or mailed to the information provided below. Torklift warrants its hitches, custom hitch receivers, frame mounted tie downs, turnbuckles, and accessories (excluding wire harnesses which carry a 90 day warranty) from date of purchase against defects in material and workmanship under normal use and service for the ownership life of the original consumer purchaser. All plastic, rubber, and/ or electrical components maintain a warranty of up to one year from the date of the purchase. **ALL COMMERCIAL APPLICATIONS ARE WARRANTED FOR A PERIOD OF 90 DAYS FROM THE DATE OF INSTALLATION/SERVICE.** Torklift will replace **FREE OF CHARGE** any part which proves defective in material or workmanship when presented to Torklift, **TRANSPORTATION CHARGES PREPAID** by purchaser, at the address above. **THIS WARRANTY IS LIMITED TO DEFECTIVE PARTS REPLACEMENT ONLY. LABOR CHARGES AND/OR DAMAGE INCURRED IN INSTALLATION OR REPLACEMENT, AS WELL AS INCIDENTAL AND CONSEQUENTIAL DAMAGES CONNECTED THEREWITH ARE EXCLUDED.** This warranty does not include the finish or paint on our products. Rusting, cracking or peeling of the finish is also excluded. Some states do not allow the exclusion or limitation of incidental or consequential damages, so the above limitation or exclusion may not apply to you. Any damage to Torklift products as a result of misuse, abuse, neglect, accident, improper installation or any use violation of instructions furnished by Torklift or **WHEN USED IN ANY COMMERCIAL APPLICATION WILL VOID THE WARRANTY.** This warranty gives you specific legal rights, and you may also have rights which vary from state to state. With warranty service, you may be able to go to a small claims court, a state court or a federal district court.



## ***INTERNATIONAL***

**322 Railroad Ave North, Kent, WA 98032**

**Phone (800) 246-8132 Fax (253) 854-8003**

**Or visit our website: [www.TorkLift.com](http://www.TorkLift.com)**

Dear Valued Customer,

Thank you for making TorkLift your choice for truck, camper packages and accessories for your vehicle. By choosing TorkLift products, you have chosen a company that has been serving the RV industry for nearly 40 years and whose name has become synonymous with strength, quality and advanced design and installation.

Please take a few moments of your time to complete the Product Registration Warranty Card on the next page. When registering your newly purchased TorkLift products, you can be assured that your contact information is secure and that you and your product are getting the attention and respect that you deserve.

Thank you again for choosing TorkLift quality products.

**Register for your lifetime warranty and receive a free Torklift International gift.**

To Fax: Send copies of the questionnaire, warranty card and receipt to  
253-854-8003

To E-mail: Send copies of the questionnaire, warranty card and receipt to  
[warranty@torklift.com](mailto:warranty@torklift.com)

To Mail: Send to Torklift International 322 Railroad Ave North, Kent, WA 98032



## OFFICIAL WARRANTY REGISTRATION CARD

**322 Railroad Ave North, Kent, Wa 98032**

Please fill out this form completely and return to Torklift within 30 days of purchase accompanied by a copy of your original receipt

### 1. PART(S) PURCHASED

TODAY'S DATE: \_\_\_\_\_

PART#: \_\_\_\_\_ PART#: \_\_\_\_\_

PART#: \_\_\_\_\_ PART#: \_\_\_\_\_

PART#: \_\_\_\_\_ PART#: \_\_\_\_\_

### 2. PURCHASER INFORMATION

NAME: \_\_\_\_\_

ADDRESS: \_\_\_\_\_

CITY: \_\_\_\_\_ STATE: \_\_\_\_\_ ZIP / POSTAL CODE: \_\_\_\_\_

PHONE: (\_\_\_\_) \_\_\_\_\_ - \_\_\_\_\_ EMAIL: \_\_\_\_\_

### 3. TRUCK INFORMATION

YEAR: \_\_\_\_\_ MAKE: \_\_\_\_\_

MODEL: \_\_\_\_\_ BED LENGTH: \_\_\_\_\_

### 4. CAMPER INFORMATION

YEAR: \_\_\_\_\_ MAKE: \_\_\_\_\_ MODEL: \_\_\_\_\_

### 5. DEALER INFORMATION

PURCHASED FROM: \_\_\_\_\_

ADDRESS: \_\_\_\_\_

CITY: \_\_\_\_\_ STATE: \_\_\_\_\_ ZIP / POSTAL: \_\_\_\_\_

INSTALLED BY: \_\_\_\_\_ OWNER ABOVE DEALER ANOTHER DEALER

IF ANOTHER DEALER, WHO: \_\_\_\_\_