

## C-506 SUB KIT

## 1997-2004 FORD F-150 & F-250 LD

7/15/2010

30,000 LBS GTW GOOSENECK KIT

\*\*\*DO NOT EXCEED VEHICLE MANUFACTURER'S RECOMMENDED TOWING CAPACITY.\*\*\*  
HAVING INSTALLATION QUESTIONS? CALL TECHNICAL SUPPORT AT 1-800-798-0813

**WARNING!!** BRAKE, FUEL, AND ELECTRICAL LINES MAY NEED TO BE LOOSENED  
OR REPOSITIONED TO PROVIDE CLEARANCE FOR NEW HARDWARE.

### INSTALLATION STEPS:

#### **Fits Light Duty Ford F-150 and F250**

1. The heat shield located above the rear axle must be removed with a 5/16" nut driver.
2. Install the forward cross member (39 7/8" long) first with the vertical leg of the angle facing rearward. It can be installed through the fender well, by sliding the angle between the frame and the truck bed.
3. Repeat step #2 for the rear cross member (39 1/8" long) The vertical leg of the rear cross member must face the front of the vehicle.

#### **Installing Side Brackets:**

**WARNING!** Brake, fuel, and electrical lines must be loosened and repositioned to provide clearance for new hardware.

4. Hang the driver side mount plate from the 5/8" welded studs extending from the ends of the cross members. Fasten the frame mount plate to the cross angles by installing 5/8" flange nuts, finger tight.
  5. Position side mount plate so that the hanger stud is aligned with clearance slot. Raise the mount plate until cross members are tight against the truck bed. C-clamp the plate to the frame and use the three attaching holes as a template to drill 1/2" diameter holes into the frame.
  6. Install a 1/2 x 2" grade 5 hex bolt and washer through side mount plate and fasten hand tight with flange nuts.
  7. Remove C-clamps.
  8. Repeat above steps for passenger side mount plate.
  9. With sub kit installed finger tight, use the 6 1/2" spacer provided to evenly space the cross members. Once correctly spaced, drill a hole through the center of each slot in the cross members up through the pickup bed.
  10. From inside the pickup bed, center the six pilot holes with the letter "A" on the cutting template. Fasten the template to the bed floor with tape. Once fastened, drill four 1/8" pilot holes through section lettered "B".  
**Be sure to check for brake and fuel lines before drilling.**
  11. With the pilot holes drilled, use a sabre saw to cut out section "C".
  12. Remove the template and set your C-1 folding hitchball into place. Using the six pilot holes as a guide, center each of the six holes in the C-1. Drill out all six holes in the pickup bed floor using a 21/32" drill bit.
  13. Assemble the folding hitchball to the cross members using six 5/8" grade 5 carriage bolts and flange nuts. Tighten bolts to 115 ft. lbs.
- Note:** Shims must be placed under each bolt, between cross members and folding hitch to prevent bed floor (corrugations) from collapsing.
14. After the C-1 has been fastened to the cross members, the remaining fasteners on the sub kit must be torqued. First secure cross members to the side mount plates using 75 ft-lbs torque. Second, secure side mount plates to the frame using 60 ft-lbs torque.
  15. Reattach any brake, fuel, and/or electrical wires so that they do not rub on added fasteners.

# C-506 SUB KIT

# 1997-2004 FORD F-150 & F-250 LD

7/15/2010

30,000 LBS GTW GOOSENECK KIT

\*\*\*DO NOT EXCEED VEHICLE MANUFACTURER'S RECOMMENDED TOWING CAPACITY.\*\*\*  
 HAVING INSTALLATION QUESTIONS? CALL TECHNICAL SUPPORT AT 1-800-798-0813

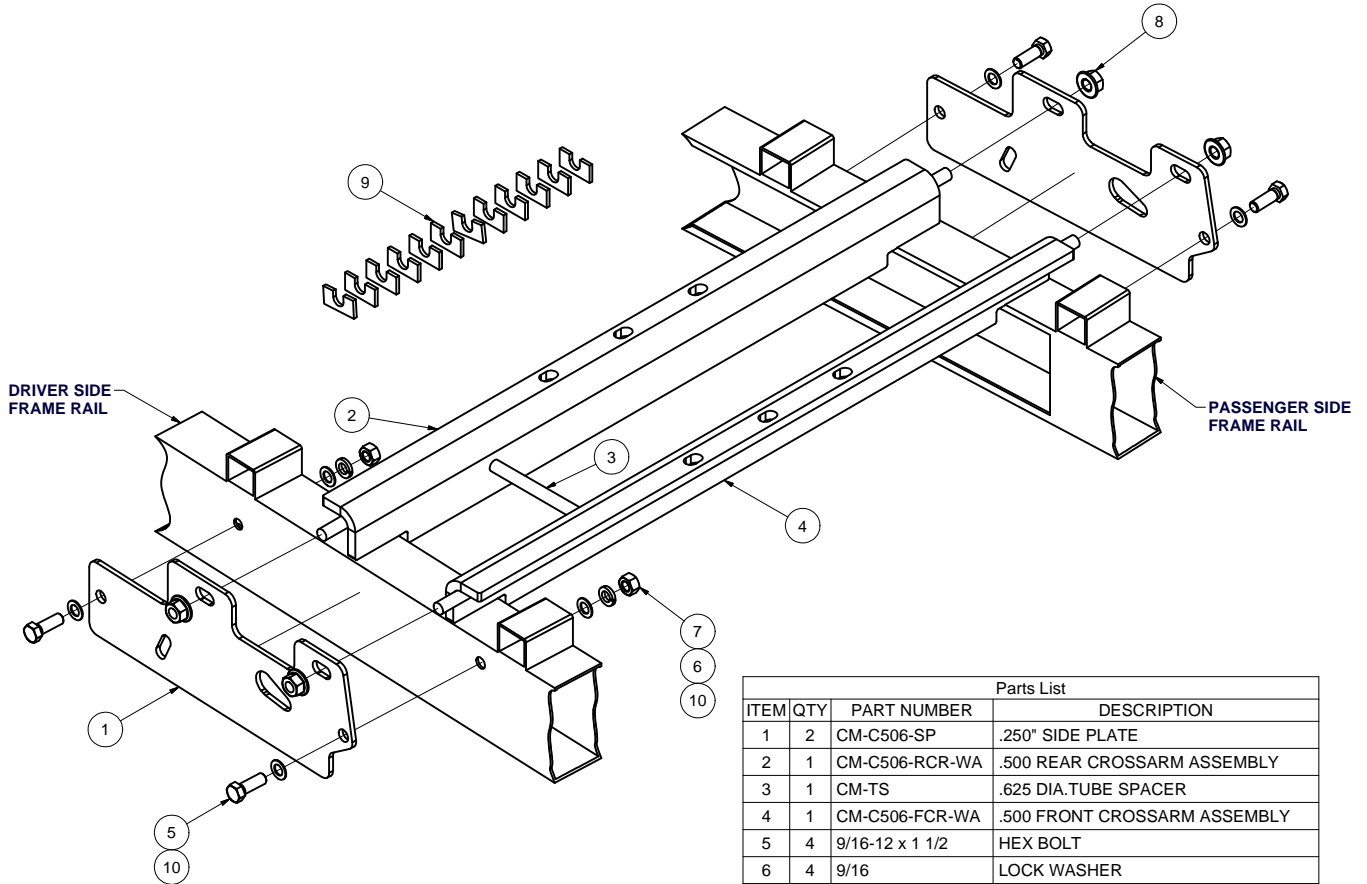

Parts List			
ITEM	QTY	PART NUMBER	DESCRIPTION
1	2	CM-C506-SP	.250" SIDE PLATE
2	1	CM-C506-RCR-WA	.500 REAR CROSSARM ASSEMBLY
3	1	CM-TS	.625 DIA. TUBE SPACER
4	1	CM-C506-FCR-WA	.500 FRONT CROSSARM ASSEMBLY
5	4	9/16-12 x 1 1/2	HEX BOLT
6	4	9/16	LOCK WASHER
7	4	9/16 - 12	HEX NUT
8	4	5/8-11	HEX FLANGE NUT
9	12	CM-SP27	.188 x 1.00 x 2.00" U-SHAPE SPACER
10	8	9_16 WASHER	FLAT WASHER

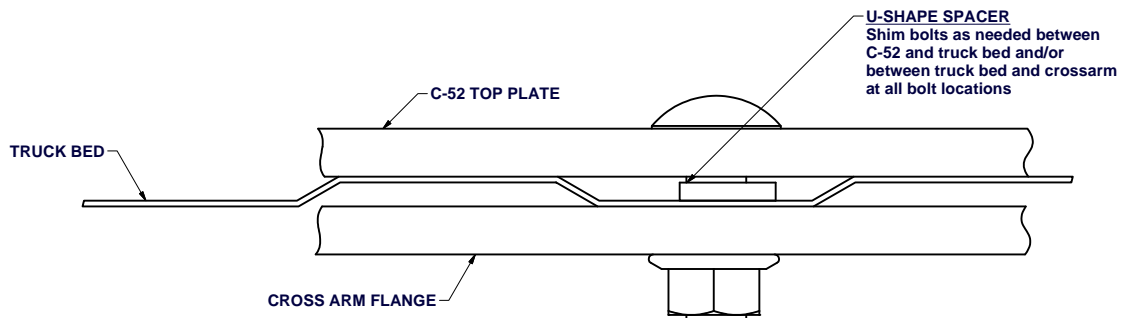

Curt Manufacturing Inc., warrants this product to be free of defects in material and/or workmanship at the time of retail purchase by the original purchaser. If the product is found to be defective, Curt Manufacturing Inc., may repair or replace the product, at their option, when the product is returned, prepaid, with proof of purchase. Alteration to, misuse of, or improper installation of this product voids the warranty. Curt Manufacturing Inc.'s liability is limited to repair or replacement of products found to be defective, and specifically excludes liability for incidental or consequential loss or damage.