

C-509

94-01 DODGE RAM 1500 ALL 94-02 2500/3500 ALL

12/28/2012

30,000 LBS GTW GOOSENECK KIT

VISIT WWW.HITCHINFO.COM FOR CURRENT APPLICATION COVERAGE,
INSTALLATION SUPPORT AND BENEFICIAL TOWING INFORMATION

Installation Instructions:

1. Install the cross members up onto the frame rails from under the truck bed by angling them up from behind the differential, over the driveshaft and exhaust. Be sure that the prepunched holes are facing upward toward the pickup bed and the vertical legs are facing toward each other.
2. Once the cross members are in position, place the driver side mount plate on the 5/8" welded studs extending from both ends of the cross members. Fasten the cross member to the side mount plate by using 5/8" flange nuts. Finger tighten only. Repeat this step for passenger side.
3. Using the 1/2" hardware provided with the kit, align the lower two holes in the side mount plate with the existing holes in the truck frame and secure them by inserting the 1/2" bolt and flat washer from the inside of the truck frame and securing them with a 1/2" flange nut. Repeat step 3 for the passenger side.
4. Once sub kit is installed, verify that the cross members and mounting plates are in their proper location.
5. Now that the sub kit is installed and only finger tight, use the spacer provided to evenly space the cross arms. Once the cross arms are spaced correctly drill a pilot hole through each of the six holes in the cross arms, up through the pick up bed. Be sure the rear cross member is approximately 3" to 6" in front of the rear axle for proper installation.
6. Place the cutting template inside the pick up bed. Align the six pilot holes with the letter A on the template. Be sure they are centered. With a piece of tape fasten the template to the pickup bed. Once fastened, drill an 1/8" pilot hole through the section letter B. Be sure to check for fuel lines, brake lines, etc before drilling.
7. Now that the pilot holes are drilled, use a sabre saw to cut out section C by connecting all the points labeled B.
8. Remove the template and set the C-1 Folding Hitch into place. Using the six pilot holes as a guide, center each of the six holes in the Folding hitch using a 21/32" drill bit. Drill through each hole down to the predrilled holes in the cross arms.
9. Using the six, 5/8" carriage bolts and flange nuts assemble the folding hitch to the cross members and fasten them securely. Tighten to 210 lb-ft using a torque wrench. Note: Before tightening, insert the spacers provided to fill the gap between the bottom of the truck bed and the top of the cross members. If not filled, this could result in cosmetic damage to the pick up bed floor.
10. After the C-1 has been fastened to the cross members, the remaining hardware on the sub assembly kit must be securely fastened. First, secure the cross members to the frame mounting plates using 210 lb-ft of torque. Second, secure the frame mounting plates to the frame; torque 1/2" hardware to 110 lb-ft.

**PERIODICALLY CHECK THIS RECEIVER HITCH TO ENSURE THAT ALL FASTENERS
ARE TIGHT AND THAT ALL STRUCTURAL COMPONENTS ARE SOUND.**

Curt Manufacturing Inc., warrants this product to be free of defects in material and/or workmanship at the time of retail purchase by the original purchaser. If the product is found to be defective, Curt Manufacturing Inc., may repair or replace the product, at their option, when the product is returned, prepaid, with proof of purchase. Alteration to, misuse of, or improper installation of this product voids the warranty. Curt Manufacturing Inc.'s liability is limited to repair or replacement of products found to be defective, and specifically excludes liability for incidental or consequential loss or damage.

C-509**94-01 DODGE RAM 1500 ALL 94-02 2500/3500 ALL**

12/28/2012

30,000 LBS GTW GOOSENECK KIT

VISIT WWW.HITCHINFO.COM FOR CURRENT APPLICATION COVERAGE,
INSTALLATION SUPPORT AND BENEFICIAL TOWING INFORMATION

Parts List			
ITEM	QTY	PART NUMBER	DESCRIPTION
1	1	CM-C509-FCA-WA	.500 FRONT CROSSARM ASSEMBLY
2	1	CM-C509-RCA-WA	.500 REAR CROSSARM ASSEMBLY
3	2	CM-C509-SP	.250" SIDE PLATE
4	4	5/8-11	HEX FLANGE NUT
5	4	9_16 WASHER	FLAT WASHER
6	4	9/16	LOCK WASHER
7	4	9/16 - 12	HEX NUT
8	4	9/16-12 x 1 3/4	HEX BOLT
9	1	CM-TS	.706 DIA.TUBE SPACER
10	12	CM-SP27	.188 x 1.00 x 2.00" U-SHAPE SPACER

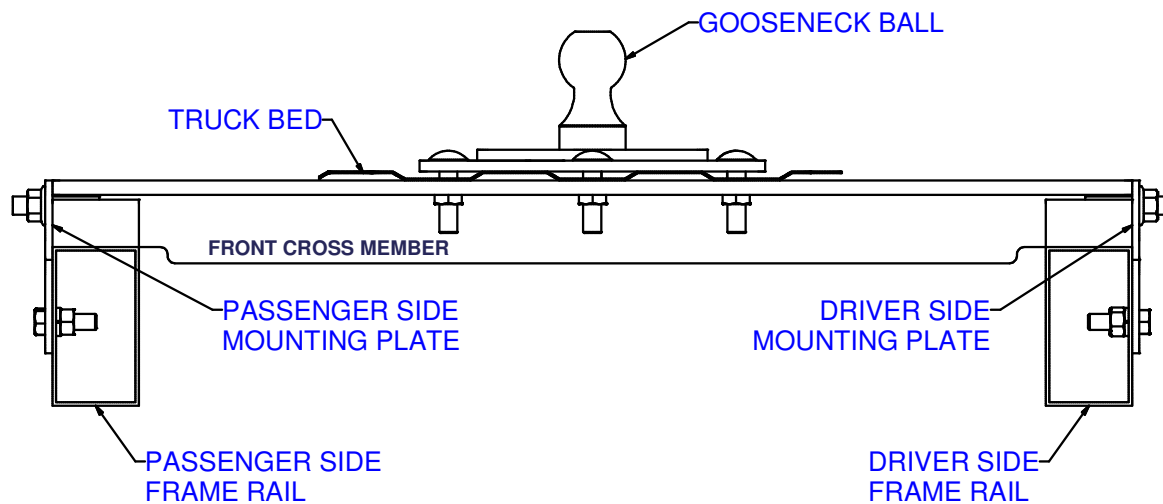
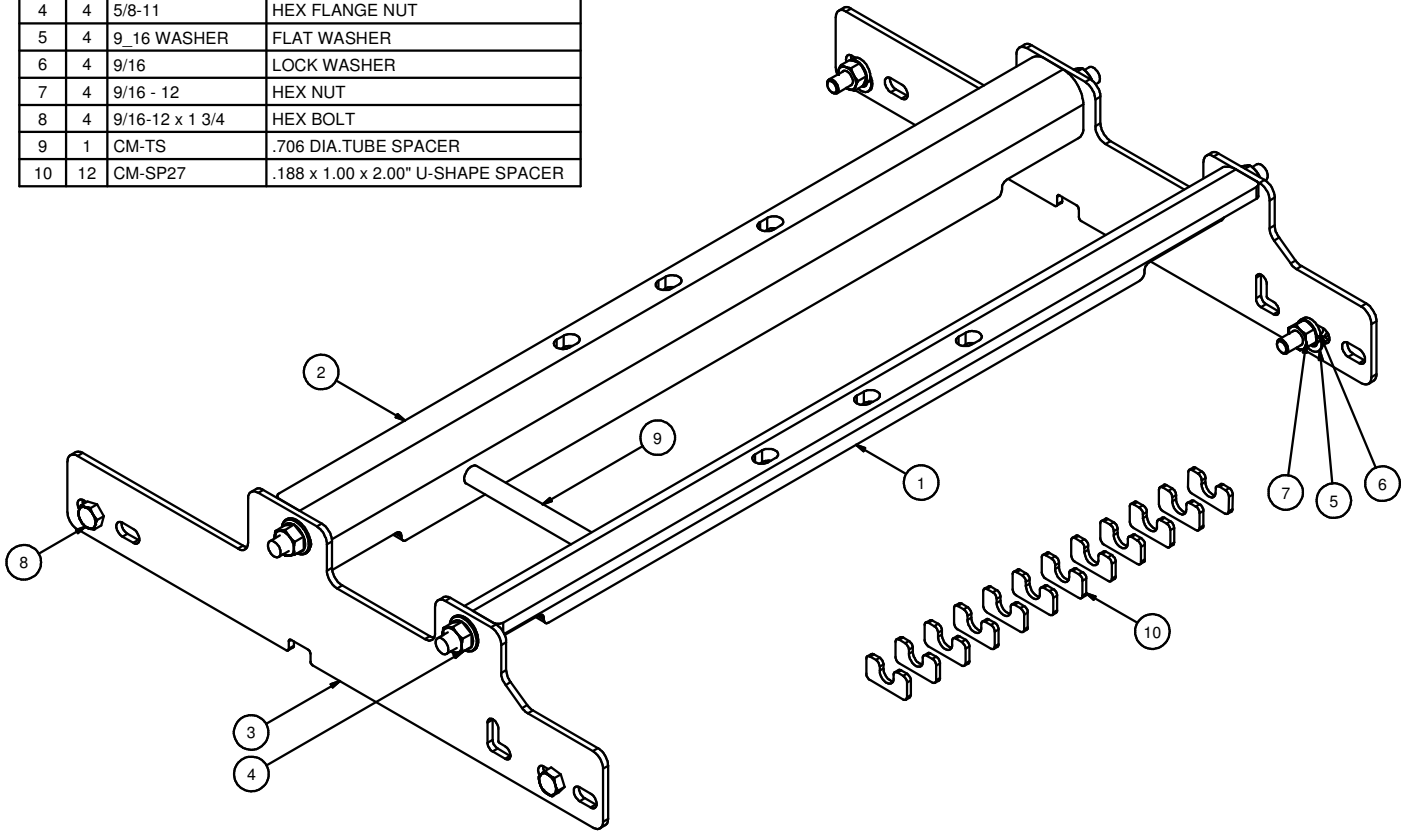

PERIODICALLY CHECK THIS RECEIVER HITCH TO ENSURE THAT ALL FASTENERS ARE TIGHT AND THAT ALL STRUCTURAL COMPONENTS ARE SOUND.

Curt Manufacturing Inc., warrants this product to be free of defects in material and/or workmanship at the time of retail purchase by the original purchaser. If the product is found to be defective, Curt Manufacturing Inc., may repair or replace the product, at their option, when the product is returned, prepaid, with proof of purchase. Alteration to, misuse of, or improper installation of this product voids the warranty. Curt Manufacturing Inc.'s liability is limited to repair or replacement of products found to be defective, and specifically excludes liability for incidental or consequential loss or damage.