

C-505 SUB KIT

1980-1996 FORD F-250 & F-350

3/4/2013

30,000 LBS GTW GOOSENECK KIT

*****DO NOT EXCEED VEHICLE MANUFACTURER'S RECOMMENDED TOWING CAPACITY.*****
HAVING INSTALLATION QUESTIONS? CALL TECHNICAL SUPPORT AT 1-800-798-0813

WARNING!! BRAKE, FUEL, AND ELECTRICAL LINES MAY NEED TO BE LOOSENEED
OR REPOSITIONED TO PROVIDE CLEARANCE FOR NEW HARDWARE.

INSTALLATION STEPS:

1. The heat shield located above the rear axle must be removed before installing. This can be done with a 7/32" nut driver. Be sure to replace the front screw after removing the shield.
2. Once the heat shield has been removed, take your prepunched heavy duty cross members and slide them between the frame rail and the bottom of the truck bed. This can be done by pushing them through from the driver side above the axle. After pushing the first one through, slide it back toward the rear of the truck. Repeat Step 2 for the second cross member and make sure the downward legs face each other.
3. Install the side mount plates by hanging them from the 5/8" welded studs extending from both ends of the cross members. Fasten the cross members to the side mount plates with 5/8" flange nuts. Finger tighten only.
4. Insert the 1" grade 5 bolt through the side mount plate then through the three 1" washers and frame, secure with a 1" flange nut. Finger tighten only. Insert a 5/8" carriage bolt through the plate and frame, secure this hardware with a flange nut. Repeat this step for the opposite side. **NOTE: Three 1" washers must be placed between the side mount plates and vehicle frame at the 1" bolt location.**
5. Now that the sub kit is installed and only finger tight, use the spacer provided to evenly space the cross members. Once the cross members are spaced correctly from the under side of the truck, drill a pilot hole through each of the holes in the cross members, up through the pick up bed. Be sure the arms are approximately 3" to 6" in front of the rear axle.
6. From inside the pickup bed align the six pilot holes with the letter A on the template. Fasten the template plate to the pick up bed with a piece of tape. Once fastened, drill four 1/8" pilot holes through the section letter B. Be sure to check for fuel & brake lines etc. before drilling.
7. Now that the pilot holes are drilled, use a sebre saw to cut out section C by connecting all the points labeled B.
8. Remove the template and set the folding hitch into place. Using the six pilot holes in the pick up bed as a guide, center each of the six holes in the folding hitch. Using a 21/32" drill bit, drill through each hole down to the predrilled holes in the cross members.
9. Assemble the folding hitch to the cross members and fasten them securely using six 5/8" grade 8 carriage bolts and flange nuts. Tighten to 250 ft-lbs using a torque wrench.
10. After the folding ball has been fastened to the cross members, the remaining hardware on the sub kit must be tightened. First, secure the cross members to the side mount plates using 250 ft-lbs of torque. Second, secure the side mount plates to the frame - torque 1/2" hardware to 110 ft-lbs and the 1" hardware to 300 ft-lbs.

C-505 SUB KIT

1980-1996 FORD F-250 & F-350

3/4/2013

30,000 LBS GTW GOOSENECK KIT

*****DO NOT EXCEED VEHICLE MANUFACTURER'S RECOMMENDED TOWING CAPACITY.*****
 HAVING INSTALLATION QUESTIONS? CALL TECHNICAL SUPPORT AT 1-800-798-0813

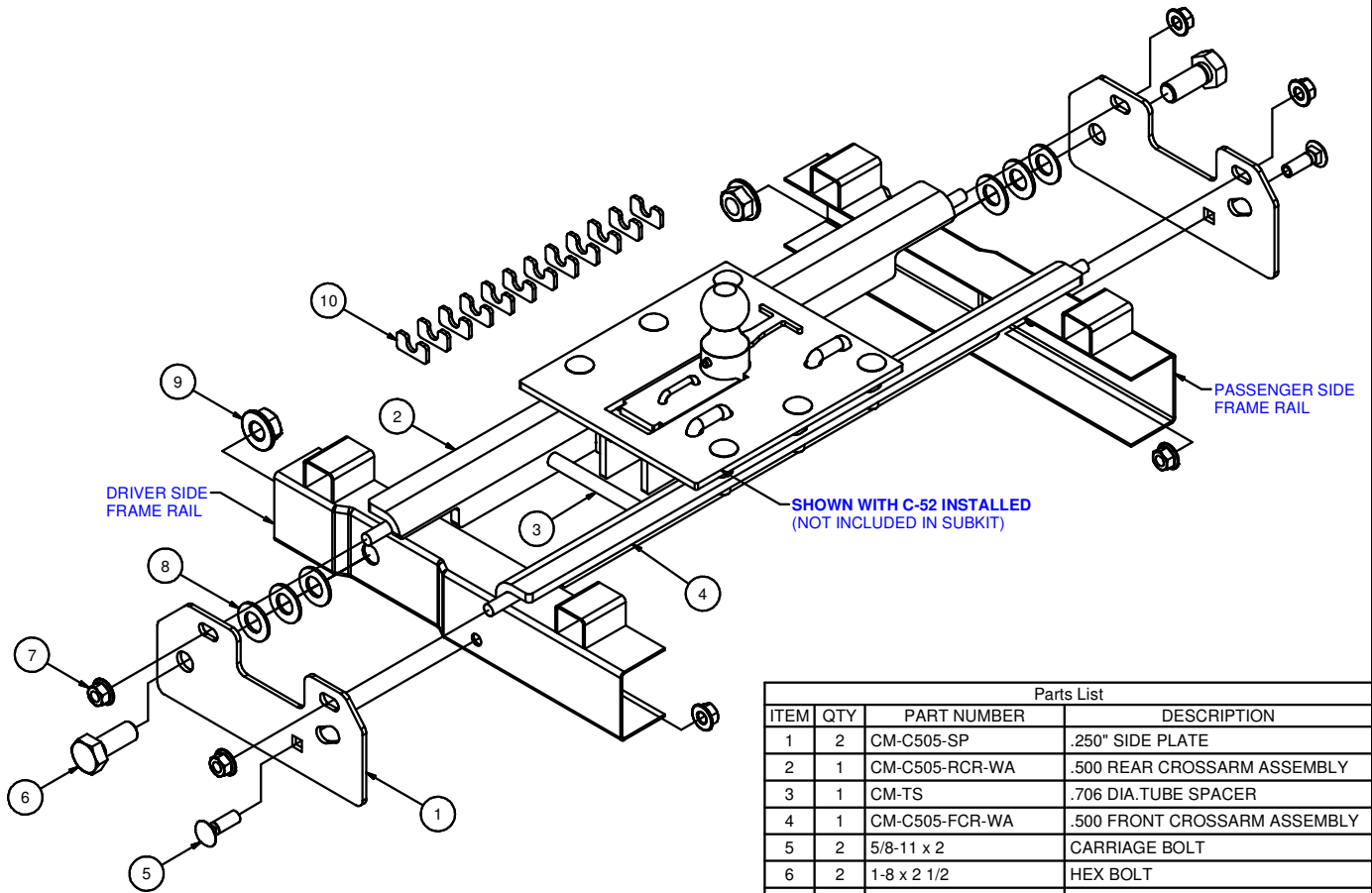

Parts List			
ITEM	QTY	PART NUMBER	DESCRIPTION
1	2	CM-C505-SP	.250" SIDE PLATE
2	1	CM-C505-RCR-WA	.500 REAR CROSSARM ASSEMBLY
3	1	CM-TS	.706 DIA. TUBE SPACER
4	1	CM-C505-FCR-WA	.500 FRONT CROSSARM ASSEMBLY
5	2	5/8-11 x 2	CARRIAGE BOLT
6	2	1-8 x 2 1/2	HEX BOLT
7	6	5/8-11	HEX FLANGE NUT
8	6	1.00 DIA.	WASHER
9	2	1 - 8 HEX FLANGE NUT	HEX FLANGE NUT
10	12	CM-SP27	.188 x 1.00 x 2.00" U-SHAPE SPACER

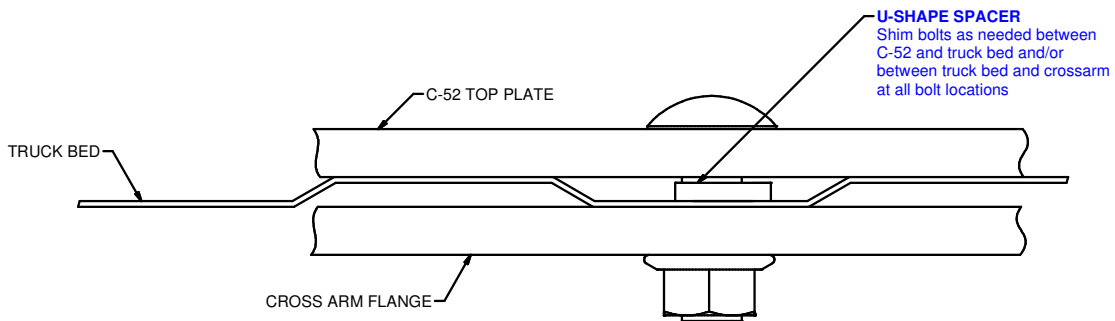

Curt Manufacturing Inc., warrants this product to be free of defects in material and/or workmanship at the time of retail purchase by the original purchaser. If the product is found to be defective, Curt Manufacturing Inc., may repair or replace the product, at their option, when the product is returned, prepaid, with proof of purchase. Alteration to, misuse of, or improper installation of this product voids the warranty. Curt Manufacturing Inc.'s liability is limited to repair or replacement of products found to be defective, and specifically excludes liability for incidental or consequential loss or damage.

CAP TO TRAILER CLEARANCE

*****DO NOT EXCEED VEHICLE MANUFACTURER'S RECOMMENDED TOWING CAPACITY.*****

HAVING INSTALLATION QUESTIONS? CALL TECHNICAL SUPPORT AT 1-800-798-0813

****REMOVAL OF REAR WINDOW ACCESSORIES MAY BE REQUIRED****

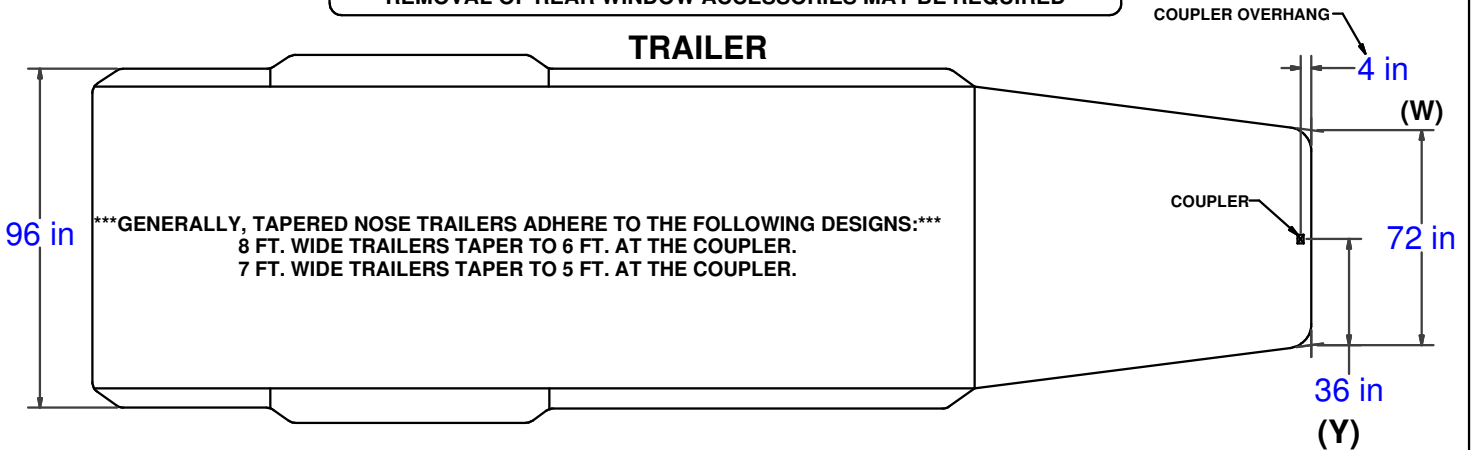

LONG & SHORT TRUCK BEDS

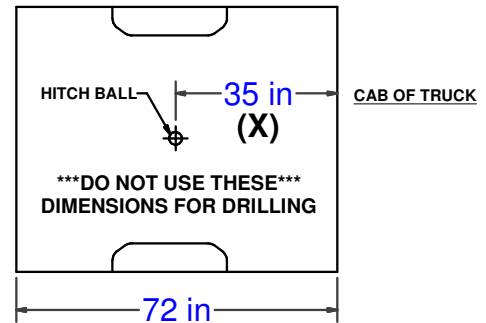
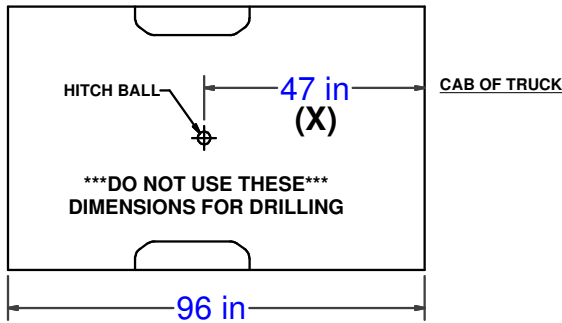

****WARNING REFERENCE CLEARANCE CALCULATOR BEFORE TOWING****

CLEARANCE CALCULATION

$$\begin{matrix} \text{(CAB TO BALL CENTER)} & - & 1/2 \text{ (TRAILER WIDTH)} & = & \text{(MINIMUM CLEARANCE)} \\ \text{(X)} & - & \text{(Y)} & = & \text{(Z)} \end{matrix}$$

IF THERE IS AN OVERHANG FROM THE COUPLER THEN THE EQUATION IS:

$$\text{[(X) - (W)]} - \text{(Y)} = \text{(Z)}$$

*****IF (Z) IS POSITIVE, TRAILER WILL NOT INTERFERE WITH CAB OF TRUCK.***
 IF (Z) IS NEGATIVE, TRAILER WILL INTERFERE WITH CAB OF TRUCK!!!**

EXAMPLE:

STANDARD TRAILER

$$X - Y = Z$$

$$35 - 36 = -1$$

(TRAILER **WILL INTERFERE** WITH CAB)

TRAILER WITH OVERHANG

$$\text{[(X) - (W)]} - Y = Z$$

$$\text{[35 - 4]} - 36 = -5$$

(TRAILER **WILL INTERFERE** WITH CAB)

YOUR CALCULATION:

(CAB TO BALL CENTER) _____

(COUPLER OVERHANG) - _____

1/2 (TRAILER WIDTH) - _____

(MINIMUM CLEARANCE) = _____