



11013 INSTALLATION INSTRUCTIONS



Safety glasses should be worn at all times while installing this product.

YEARS: 2010

MAKE: CADILLAC

MODEL: CTS

STYLE: SPORT WAGON

WARNING: NEVER EXCEED YOUR VEHICLE MANUFACTURER'S RECOMMENDED TOWING CAPACITY

WEIGHT CARRYING:
TRAILER WEIGHT: 2,000 LBS.
TONGUE WEIGHT: 200 LBS.

WARNING:
WE RECOMMEND THE USE OF 18050 STABILIZING STRAPS FOR ALL NON-TRAILER (WHEEL-LESS) LOADS. PLEASE SEE THE CURT CATALOG OR VISIT US ONLINE AT WWW.CURTMFG.COM FOR FURTHER INFORMATION.

INSTALLATION TIME: 30 MIN.

THE INSTALL TIME LISTED IS FOR PROFESSIONAL INSTALLERS. IF YOU ARE HESITANT TO UNDERTAKE THIS TASK ON YOUR OWN, CONTACT AN AUTHORIZED CURT INSTALLER FOR ADDITIONAL ASSISTANCE.

INSTALLATION TIPS:

1. BEFORE YOU BEGIN INSTALLATION, READ ALL INSTRUCTIONS THOROUGHLY.
2. TO EASE INSTALLATION, 2 PEOPLE MAY BE REQUIRED.
3. USING PROPER TOOLS WILL GREATLY IMPROVE THE QUALITY OF THE INSTALL AND REDUCE THE TIME REQUIRED.
4. NEED HELP OR HAVE SOME QUESTIONS? CALL TECHNICAL SUPPORT AT 800.798.0813

VEHICLE PHOTO:





REPRESENTATIVE PHOTO

INSTALLATION REQUIRES:

 RATCHET	 13 mm 7/16 in SOCKET	 DIE GRINDER
 PRY BAR	 SPRAY LUBRICANT	 TORQUE WRENCH
 SAFETY GLASSES	 MASKING TAPE	

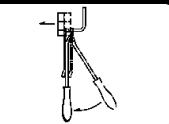
LEVEL OF DIFFICULTY: MODERATE

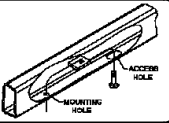
EASY	MODERATE	HARD
	MUST REMOVE (6) REARMOST EXHAUST HANGERS	
	ENLARGE DRIVER SIDE ACCESS HOLE	
	FISHWIRE HARDWARE	

HITCH ILLUSTRATION:

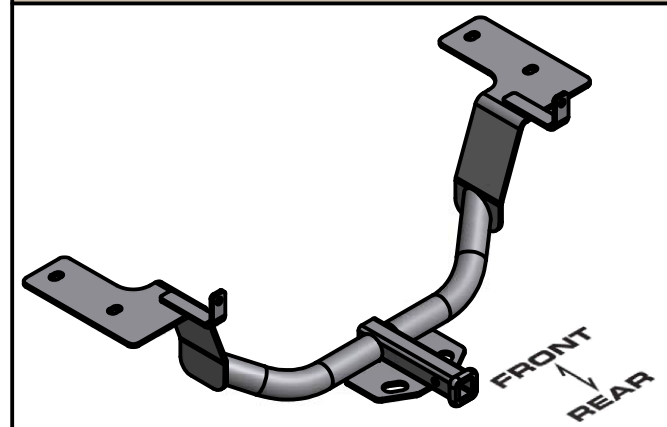

MAKE SURE YOUR HITCH MATCHES

PERIODICALLY CHECK THIS RECEIVER HITCH TO ENSURE ALL FASTENERS ARE TIGHT AND ALL STRUCTURAL COMPONENTS ARE SOUND

CURT Manufacturing Inc. warrants this product to be free of defects in material and/or workmanship at the time of retail purchase by the original purchaser. If the product is found to be defective, Curt Manufacturing Inc. may repair or replace the product at their option, when the product is returned, prepaid, with proof of purchase. Alteration to, misuse of, or improper installation of this product voids the warranty. Curt Manufacturing Inc.'s liability is limited to repair or replacement of products found to be defective, and specifically excludes liability for incidental or consequential loss or damage.

For more information log onto www.curtmfg.com, & for helpful towing tips log onto www.hitchinfo.com

INSTALLATION WALKTHROUGH:

Parts List			
ITEM	QTY	PART NUMBER	DESCRIPTION
1	4	7/16-14 x 1 1/4	CARRIAGE BOLT
2	4	CM-SP2	SQUARE HOLE SPACER
3	4	7/16-14	LARGE HEX FLANGE NUT
4	2	7_16 FISHWIRE	7/16" FISHWIRE

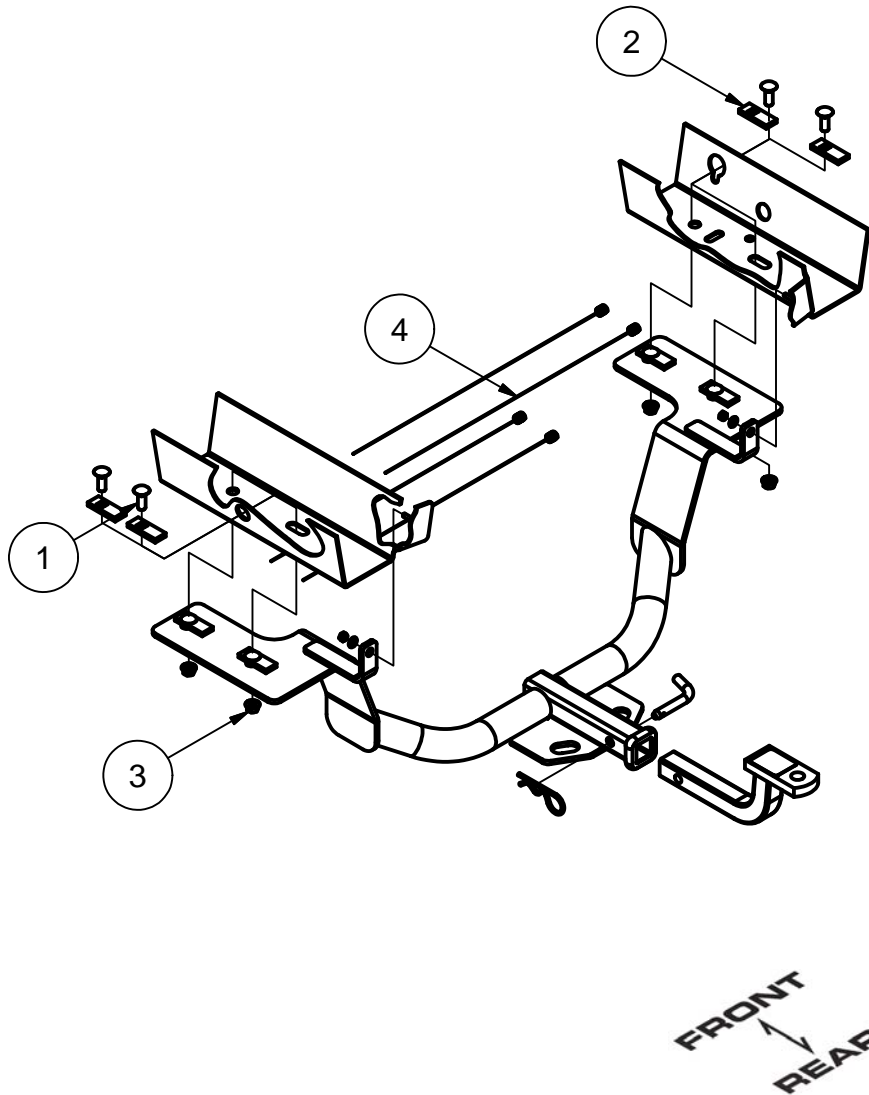

1. Remove (3) plastic plugs that attach rear fascia to underbody.

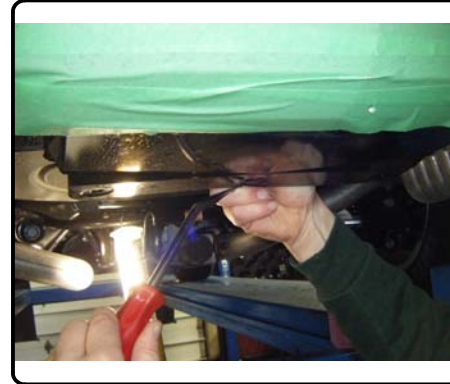

2. Lower exhaust by removing (6) rubber isolators.



INSTALLATION WALKTHROUGH:

3. Lower exhaust below fascia.



4. Enlarge access hole on driver side frame rail to allow included hardware to pass through.



DIE GRINDER

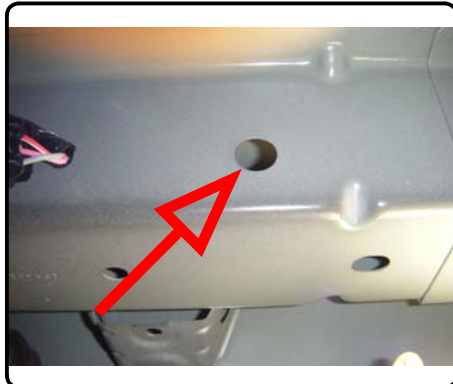

5. Remove nut from the post which is located on the inside of the frame rail, above the exhaust hanger, on the rearmost part of frame. Remove this nut from both sides.



6. Raise hitch into position and attach to existing posts using the nuts that were removed in step 5.

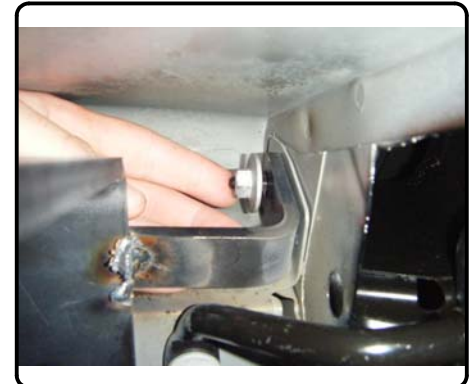
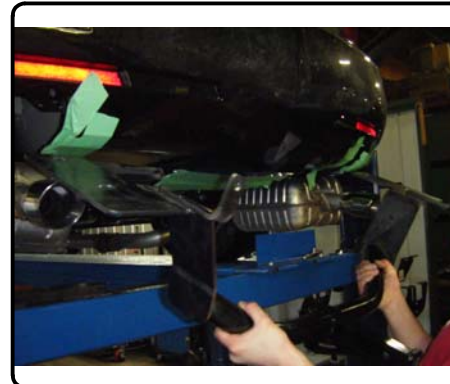

INSTALLATION WALKTHROUGH:

7. Fishwire hardware through access holes and fasten hitch to frame.



8. Torque all 7/16 in. hardware to 50 ft-lbs.



9. Raise exhaust back into position.



11013**CADILLAC CTS SPORT WAGON**

1/12/2010

GROSS LOAD CAPACITY WHEN USED AS A WEIGHT CARRYING HITCH: 2,000 LBS. TRAILER WEIGHT & 200 LBS. TONGUE WEIGHT.*****DO NOT EXCEED VEHICLE MANUFACTURER'S RECOMMENDED TOWING CAPACITY.*******WARNING: ALL NON-TRAILER LOADS APPLIED TO THIS PRODUCT MUST BE SUPPORTED BY 18050 STABILIZING STRAPS.****** FAILURE TO PROPERLY SUPPORT NON-TRAILER LOADS WILL VOID PRODUCT WARRANTY******HAVING INSTALLATION QUESTIONS? CALL TECHNICAL SUPPORT AT 1-800-798-0813**

Parts List				
ITEM	QTY	PART NUMBER	DESCRIPTION	
1	4	7/16-14 x 1 1/4	CARRIAGE BOLT	
2	4	CM-SP2	.250 x .88 x 2.25" SQUARE HOLE SPACER	
3	4	7/16-14	LARGE HEX FLANGE NUT	
4	2	7_16 FISHWIRE	7/16" FISHWIRE	

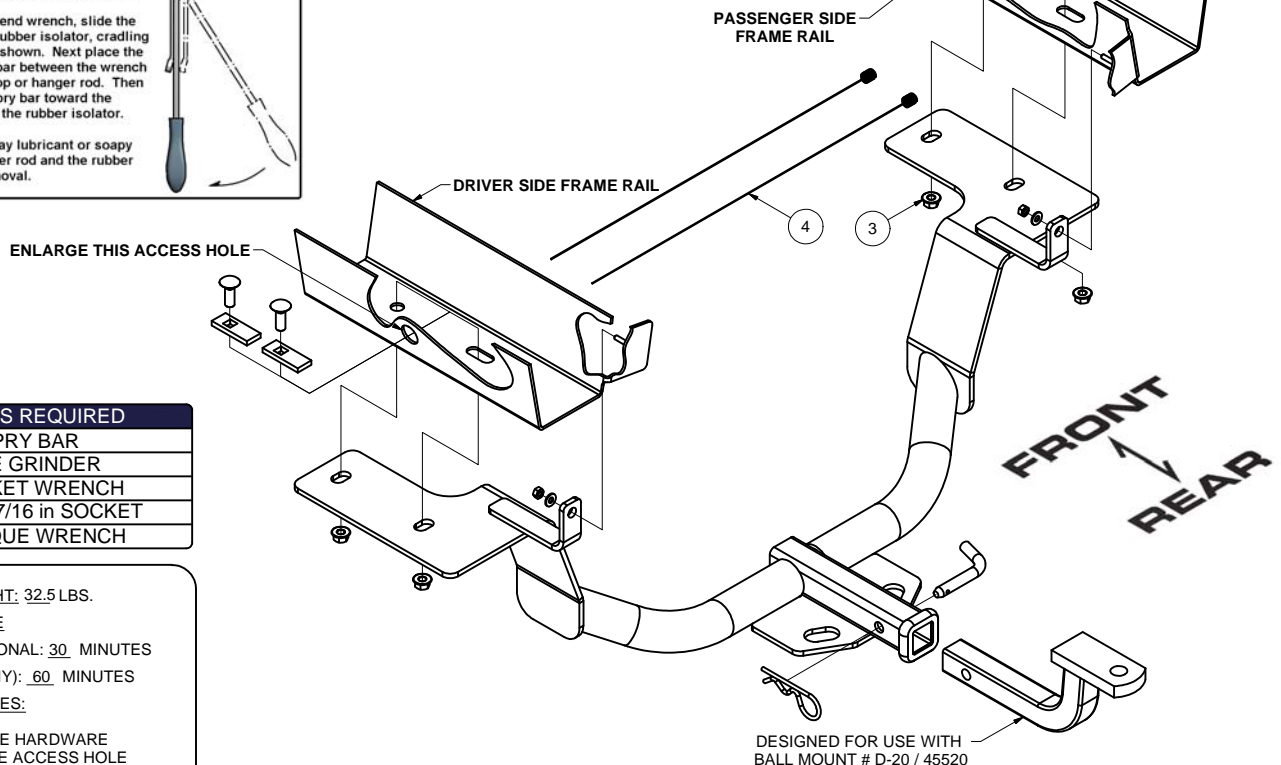
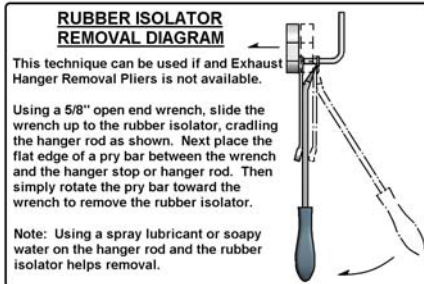
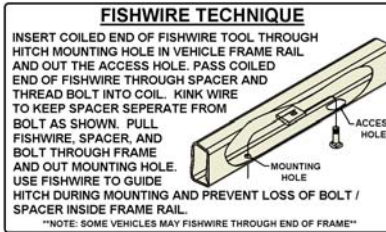
**TOOLS REQUIRED**

PRY BAR
DIE GRINDER
SOCKET WRENCH
13mm, 7/16 in SOCKET
TORQUE WRENCH

HITCH WEIGHT: 32.5 LBS.

INSTALL TIME

PROFESSIONAL: 30 MINUTES

NOVICE (DIY): 60 MINUTES

INSTALL NOTES:

-FISHWIRE HARDWARE
-ENLARGE ACCESS HOLE

INSTALLATION STEPS

1. Remove (3) plastic plugs that attach rear fascia to underbody.
2. Lower exhaust by removing (6) rubber isolators. (See RUBBER ISOLATOR REMOVAL DIAGRAM above)
3. Lower exhaust below fascia.
4. Enlarge access hole on driver side frame rail to allow included hardware to pass through.
5. Remove nut from post which is located on the inside of the frame rail, above the exhaust hanger, on the rearmost part of frame. Remove this nut from both sides.
6. Raise hitch into position and attach to existing posts using the nuts that were removed in step 4.
7. Fishwire hardware through access holes and fasten hitch to frame. (See FISHWIRE TECHNIQUE above)
8. Torque all 7/16 in. hardware to 50 ft-lbs.
9. Raise exhaust back into position.

PERIODICALLY CHECK THIS RECEIVER HITCH TO ENSURE THAT ALL FASTENERS ARE TIGHT AND THAT ALL STRUCTURAL COMPONENTS ARE SOUND.

Curt Manufacturing Inc., warrants this product to be free of defects in material and/or workmanship at the time of retail purchase by the original purchaser. If the product is found to be defective, Curt Manufacturing Inc., may repair or replace the product, at their option, when the product is returned, prepaid, with proof of purchase. Alteration to, misuse of, or improper installation of this product voids the warranty. Curt Manufacturing Inc.'s liability is limited to repair or replacement of products found to be defective, and specifically excludes liability for incidental or consequential loss or damage.